

How to Build

Flash/Stun Grenades



George Dmitrieff

How to Build Flash/Stun Grenades

By
George Dmitrieff

OCR by Enkidu
Rogue Science
De Rerum Omnis

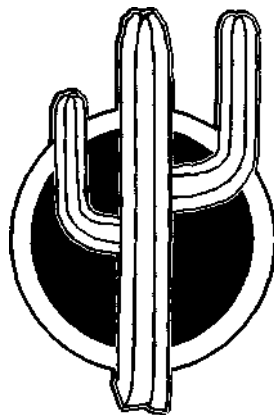

Desert Publications
El Dorado, AR 71731-1751

Introduction

The present volume is a continuation of a series of monographs on weapons use by individual combat personnel, i.e. submachine guns, grenades, etc.

As in previous volumes, the emphasis is on simplicity without sacrificing the product performance. Simple design, simple processes and common language terms are used. It is common in any professional field to show-off expertise by using words or phrases, which although correct and proper, could be substituted with simple ones. Example, "decanting" is substituted for "pour-off" and "at this point in time" is simplified to "now."

The format of presentation is similar to that used by junior college science laboratory texts. Preference is given to pictures and sketches over words. However, it must be noted that this text is intended as an introduction into the field only. It is a theoretical study, even though the processes and safety instructions are based on data and expertise of ordnance and military specifications.

It is emphasized that the processes described are dangerous due to the sensitive nature of the materials used. Furthermore, possession and construction of these devices is subject to Federal, State, and local laws and regulations requiring special license.

Lastly, the author and publishers do not in any way promote or solicit advertising for or against any products or manufacturers mentioned in the text.

Historical Notes

The method of incapacitating targets by blinding has been used since the beginning of time, by insects, animals and man. The first written reference is on Archimedes who used shields as mirrors to reflect sunlight into the eyes of attackers at Syracuse, Sicily in 212 BC. The Byzantine emperor Basil II, in 1014 blinded his prisoners of war permanently eliminating them as future enemies. Renaissance princes blinded their political opponents for the same reason. In both instances the humane influence of the Church, "thou shall not kill." was observed.

The various gases used in WW I not only destroyed the lung tissue, but also had the secondary effect of attacking the eye of the target. The use of illuminating flares in night fighting as means of temporary blinding also limited use in WW II.

Lasers to blind the pilots and/or the crews of anti-aircraft guns did receive favorable attention in some quarters in recent years. Lastly, the blinding effect of the flash became a favorite method of incapacitation of terrorists by the various commando units.

Warning

The manufacture of explosives such as flash/stun grenades is *illegal* without proper authority and licenses from the Bureau of Alcohol, Tobacco, and Firearms. Do not use this book to construct the described parts and grenades without licenses and authorization from this agency. Further, authorization from the proper agencies on the local and state level may be required.

The procedures in this book are dangerous and result in products that are extremely dangerous. Whenever dealing with explosives of any type, all precautions as set forth in industry standards for experimentation and production of high explosives should be strictly adhered to. Failure to strictly follow the industry standards may result in either physical injury or death. Therefore, the information in this book is presented solely *for academic purpose only*. Neither the author, publisher nor distributors of this book assume any responsibility for the use or misuse of information contained herein.

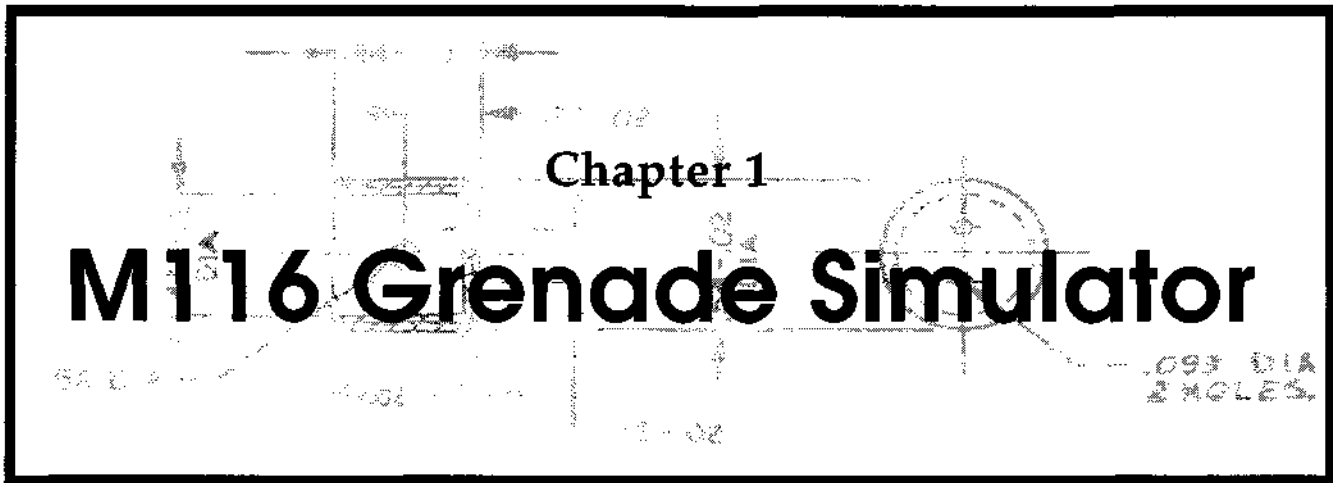

The subject of this work is expedient flash grenades which blind and/or illuminate the target. The standard hand grenade simulator, the flash grenade, and the illuminating grenade all fall into this category. They all have a common characteristic, the type of filler. Whereas in a fragmentation grenade the filler is a high explosive (HE), requiring a detonator to set it off, the filler in a flash device is a pyrotechnic mix ignited by flame or spark only. Such pyrotechnic filler in addition to the blinding action has an effect similar to an offensive-blast grenade, when used in a room, vehicle, aircraft, or other enclosed space.

The difference between a grenade simulator and a flash-illuminating grenade is essentially in the quantity of the filler charge (35 gram vs. 120 gram) and in the more elaborate and expensive containers and igniters.

The question is asked, if the pyrotechnic flash filler allows such simple grenade construction, why use the HE filler. Unfortunately there are also disadvantages. Firstly, a flash filler, weight for weight, is not as powerful as a generally used high explosive. Secondly, flash mixes are more sensitive to handling than HE.

The U. S. Army presently uses the M116A1 grenade simulator and the Mk1 illuminating grenade (DODIC #1330-G895) described below. There are also commercially available flash grenades such as the well known model 429 "Thunderflash" by Accuracy Systems, Inc., Phoenix, Arizona and the new stun grenade from Quimica Tupan, Rio de Janeiro, Brazil.

Simulator, hand grenade, M116Weight: 97 grams

Functioning:

- 1 - remove safety clip from fuse lighter
- 2 - pull off cap carefully until cord is free of fuse lighter
- 3 - holding the simulator firmly in the throwing hand, jerk the cord with the other hand and throw the simulator immediately.

How to Build Flash/Stun Grenades

Operation:

- 1 - the jerking of the cord pulls the ripple wire through the ignition mix igniting it
- 2 - the ignition mix in turn ignites the fuse which after 6-10 seconds burning time ignites the photoflash powder.

Note:

- 1 - the simulator acts as a blasting grenade with a radius of 5 meters and is dangerous especially in closed spaces
- 2 - dry materials (leaves, grass, etc.) may be ignited within a radius of 5 meters
- 3 - the simulator blast is of 140 dcbl minimum sound level
- 4 - the simulator make an effective expedient blast type grenade

Safety:

The simulator should be thrown to function at a minimum distance of 15 feet from personnel. The explosive action is such that gravel, sticks, and the like, may be projected at high velocity. Care should be taken to see that the simulator is thrown on ground that is free of projectable or flammable objects.

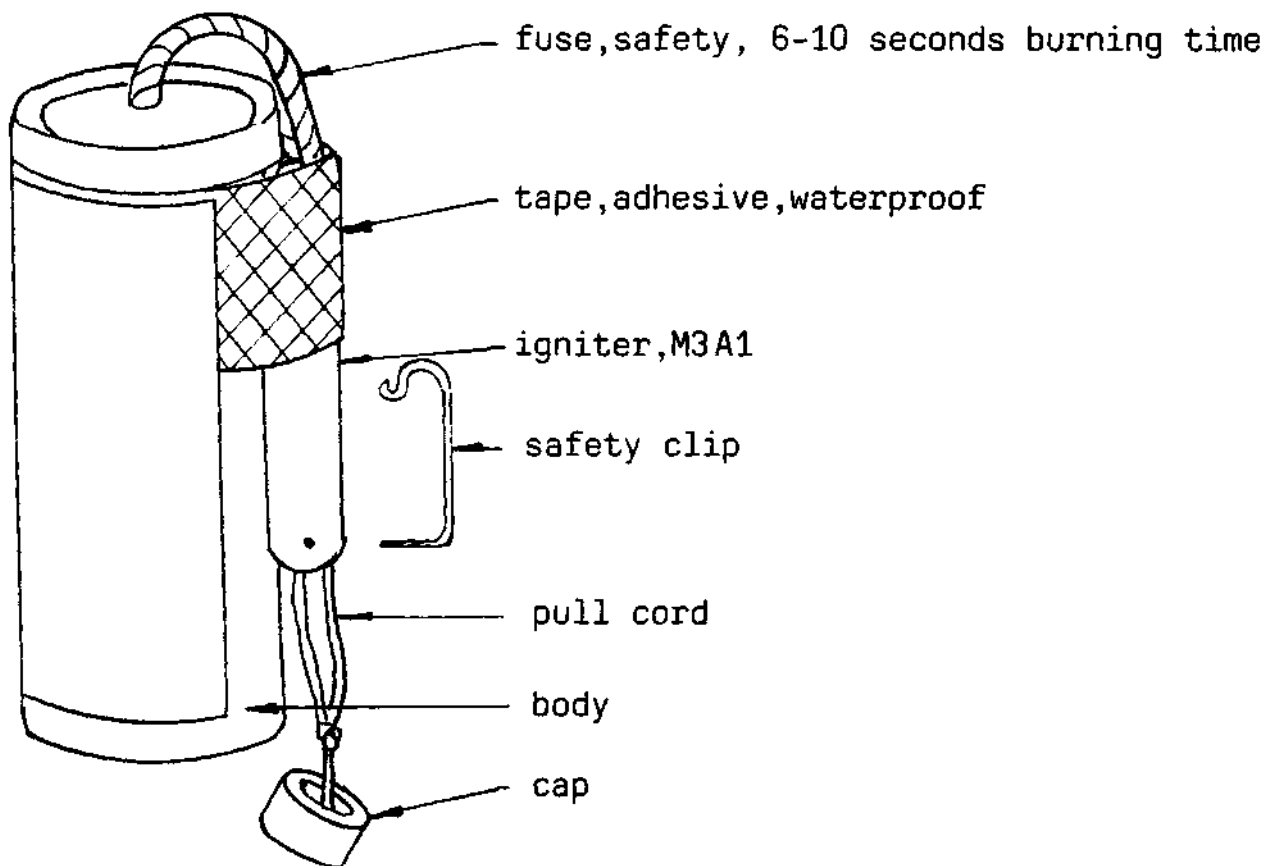

MI 16 Grenade Simulator

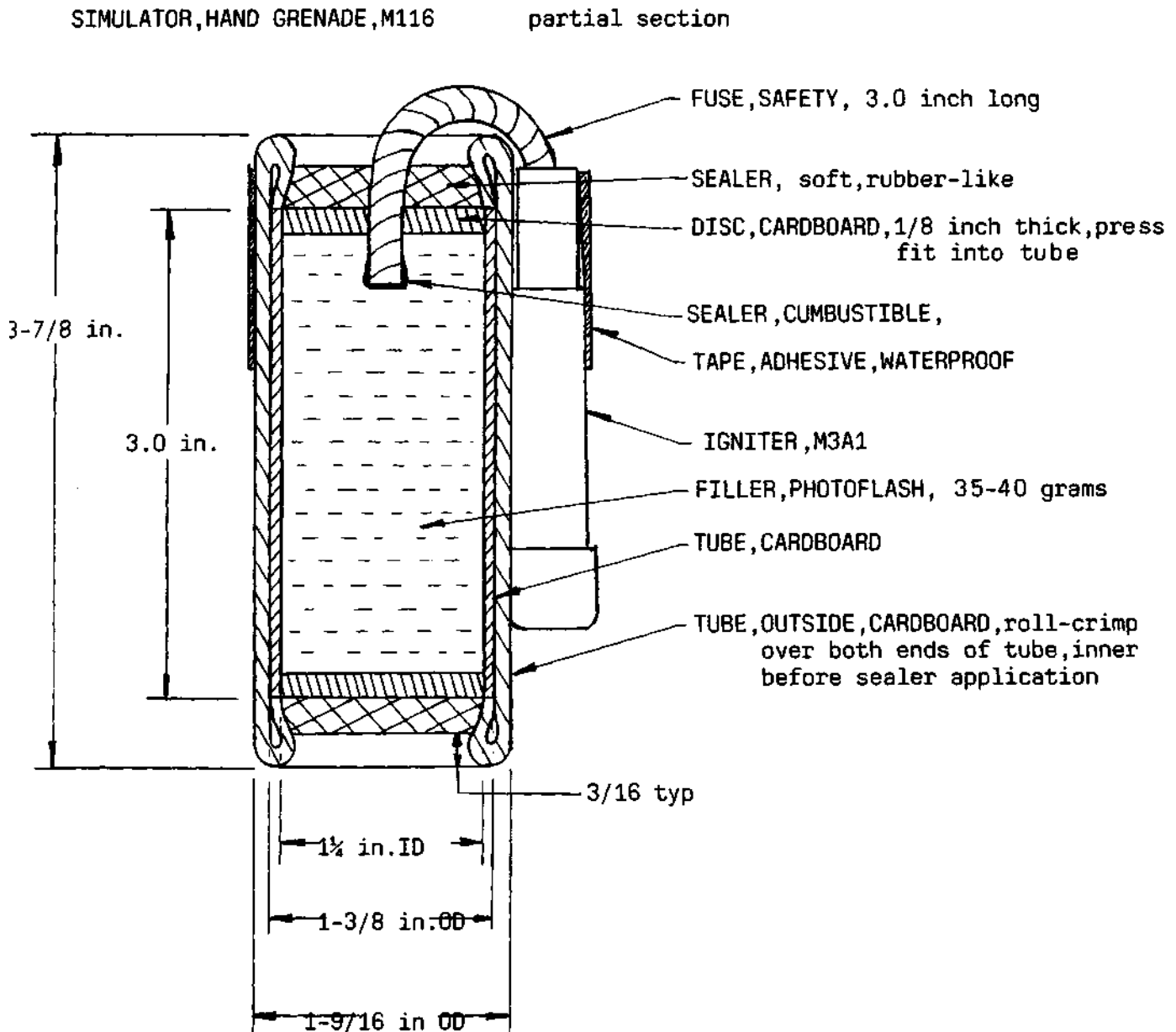

A sound approach to any problem is to take a good look at what's been done before. This not only avoids re-inventing the wheel but also leads to thinking why certain materials and methods were used. Therefore, a good look at a typical grenade simulator (M116) is in order.

As seen in the picture, this simulator consists of the four basic elements:

- 1 - Igniter
- 2 - Delay

How to Build Flash/Stun Grenades

- 3 - Filler
- 4- Body

These elements are described in detail below.

1 - Igniter

This particular igniter (M4A1) is the standard friction type, pull actuated model. It is the simplest yet quite reliable system. Similar igniter has been used on the venerable hand grenade Mod. 24 in service with the German Army through two World Wars. The M3A1 igniter construction is shown below. The numbers indicate both part and drawing number.

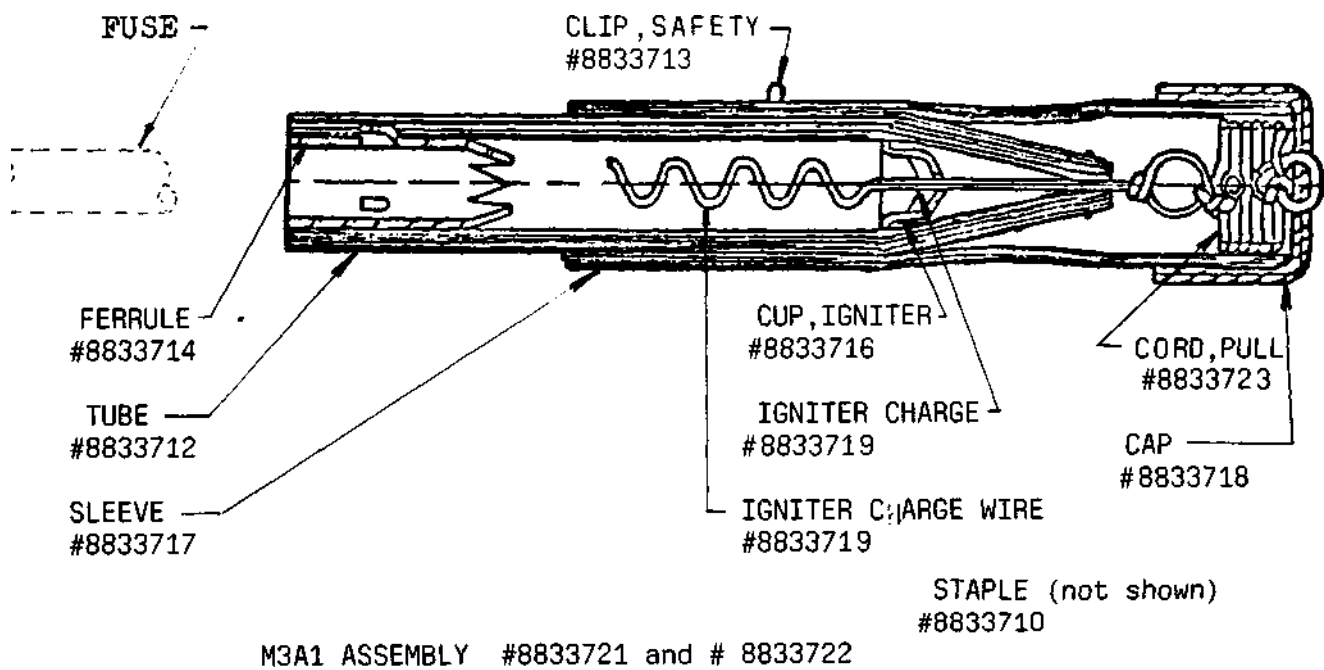

Notes:

1 - The cap and cord are provided to give the user a good grip and to assure that the wire is pulled through by a powerful jerk. A slow steady pull will not ignite the mix in the cup.

2 - the ferrule is provided to allow an easy and positive assembly of the fuse and the igniter. The ferrule prongs are bent inward so that the fuse is easily pushed in but cannot be withdrawn without force. The ferrule is necessary mainly for the use of the M3A1 igniter in the field demolition assembly; the use of this igniter for a simulator is only one specific application.

3 - the assembly of fuse and igniter is taped over with several turns of a plastic adhesive tape; this not only makes the joint solid, but also waterproof.

4 - the igniter charge in the cup consists of the following mix:

MI 16 Grenade Simulator

Material	% by weight
Potassium chlorate	88
Charcoal	10
Binder (sugar or dextrin)	2

5 - the friction mix on the wire consists of the following:

Material	% by weight
Red phosphorus	60
Shellac (1 gram) -ethanol (10ml) Solution	40

IGNITER, M3A1

Parts List:

8833710 Staples
8833712 Tube
8833713 Clip, safety
8833714 Ferrule (fuse holding)
8833715 Ferrule (obsolete)
8833716 Cup, igniter
8833717 Sleeve
8833718 Cap
8833719 Wire, igniter charge
8833721 Assembly
8833722 Assembly with cord
8833723 Cord, pull
8835011 Box, packing
8835012 Carton, packing
92123301 Adhesive (tube & sleeve)
9347369 Adhesive (tube winding)

How to Build Flash/Stun Grenades

IGNITER, M3A1 Document List

Number	Reference	Part No.
O - A - 51	Acetone	8833719
MIL-STD- 105	M3A1	
MIL-P-116	Preservation method	
MIL-P- 150	Potassium chlorate	8833719
MIL-STD- 171	Protective finish	8833713
JAN - C - 178	Charcoal	8833719
UU - P - 268	Paper	8833712
TT-S-271	Shellac	8833719
QQ - Z - 325	Zinc plating	M3A1
L - P- 398	Plastic	8833718
QQ-P-416	Plating	M3A1
QQ-W-461	Wire	8833719
MIL - E - 463	Ethanol	8833716
QQ - W - 470	Wire	8833713
O - T - 620	Trichlorethane	8833716
MIL-P-670	Phosphorus	8833719
O - E - 760	Ethanol	8833719
MIL-STD- 1234	Pyrotechnics	M3A1
MIL - A - 2550	Ammo, gnl. specs	
MIL - D - 3994	Dextrin	8833719
MIL-B- 10854	Binder	8833719
MIL-I- 12597	M3A1 igniter product specs.	
MIL-A- 13374	Adhesive	8833712
MIL-F-20412	Fuse	M3A1
MIL-C-21768	Copper alloy	8833716
MIL - A - 48078	Ammo quality	

MI 16 Grenade Simulator

Part No. 8833712
TUBE
(Component of part
No. 8833722 M3A1 igniter)

Material: Kraft paper, type I, grade A or B, spec. UU-P-268 (60 lb. wt. advisory)

Material is spiral wound with polyvinyl acetate resin emulsion part No. 9347369 between layers, or convolute wound with dextrin adhesive MIL - A 13374, class I, between layers

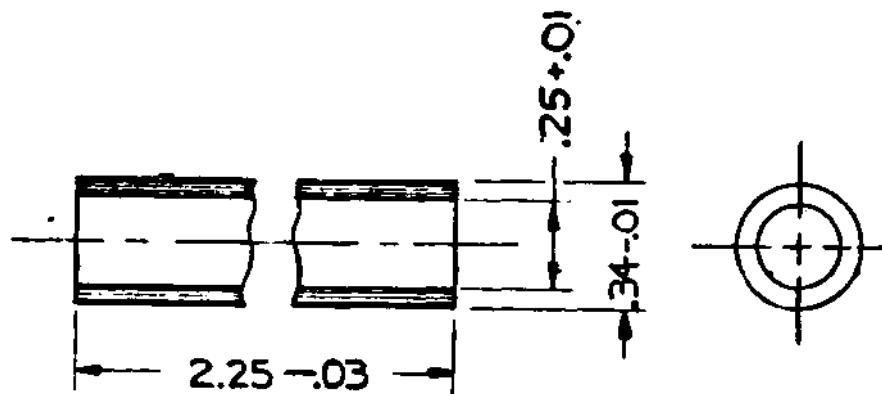

MI 16 Grenade Simulator

Part No. 8833714
FERRULE
(component of part
No. 8833722 M3A1 igniter)

Material: Steel, strip, No. 1, or No. 2 finish, ASTM A109

Protective finish: MIL - STD - 171, finish No. 1.1.2.3 or 1.9.2.3 plating thickness is advisory, provided all other requirements are met.

Notes: 1 - Spec. MIL - A - 2550 and ANSI Y14.5-1973 apply
2 - Untoleranced dimensions need not be gauged.

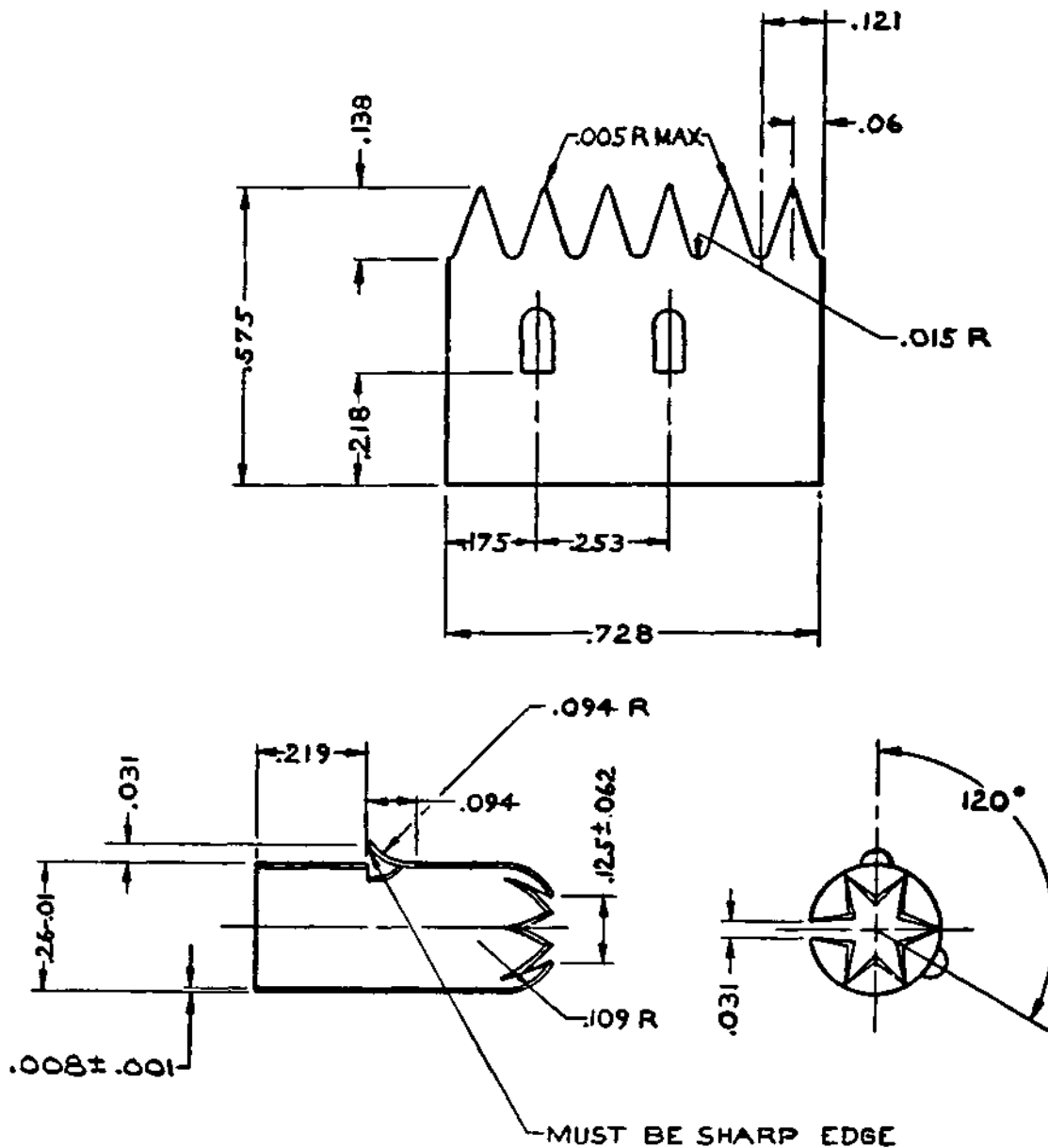

How to Build Flash/Stun Grenades

Part No. 8833715
FERRULE (OBSOLETE)
(Component of part
NO. 8833722 M3A1 igniter)

Material: Steel, strip, No. 1 or No. 2 finish, ASTM A109

Protective Finish: MIL-STD-1771, finish No. 1.1.2.3 or 1.9.2.3

Plating thickness is advisory, provided all other requirements are met.

Notes: 1 - Spec. MIL - A - 2550 applies

2 - Untoleranced dimensions need not be gauged,

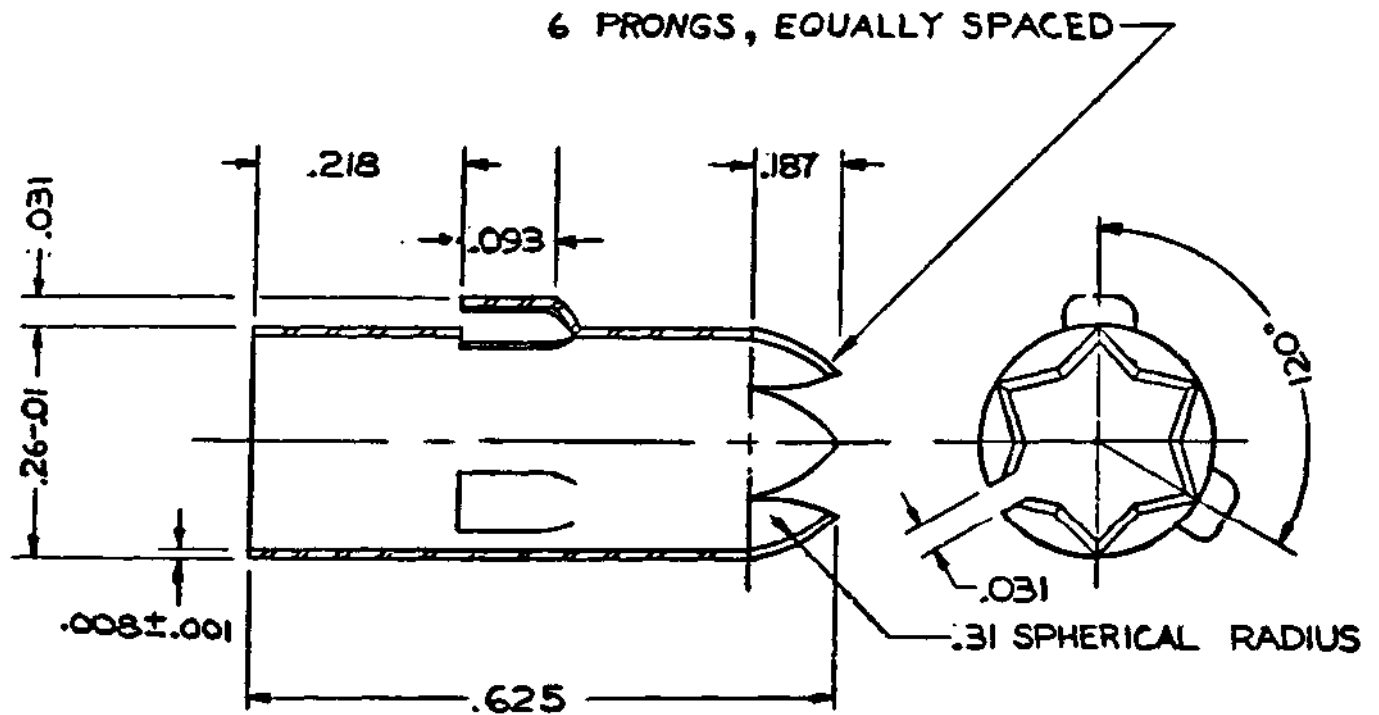

MI 16 Grenade Simulator

Part No. 8833716
CUP, IGNITER
(Component of part-
No. 8833719 M3A1 igniter)

Material: Copper alloy No. 210 annealed, spec. MIL - C - 21768

- Notes: 1 - Spec. MIL - A - 2550 and ANSI Y14.5-1973 apply
2 - After forming:
- a - Degrease in 1-1-1 trichloroethane bath, spec. O - T - 620, type I, then
 - b - apply thin coating of 7-15 grams orange shellac, spec. TT - S - 271, type I, form a, grade A or B in 200 m. ethyl alcohol, spec. MIL - E 463, grade 5

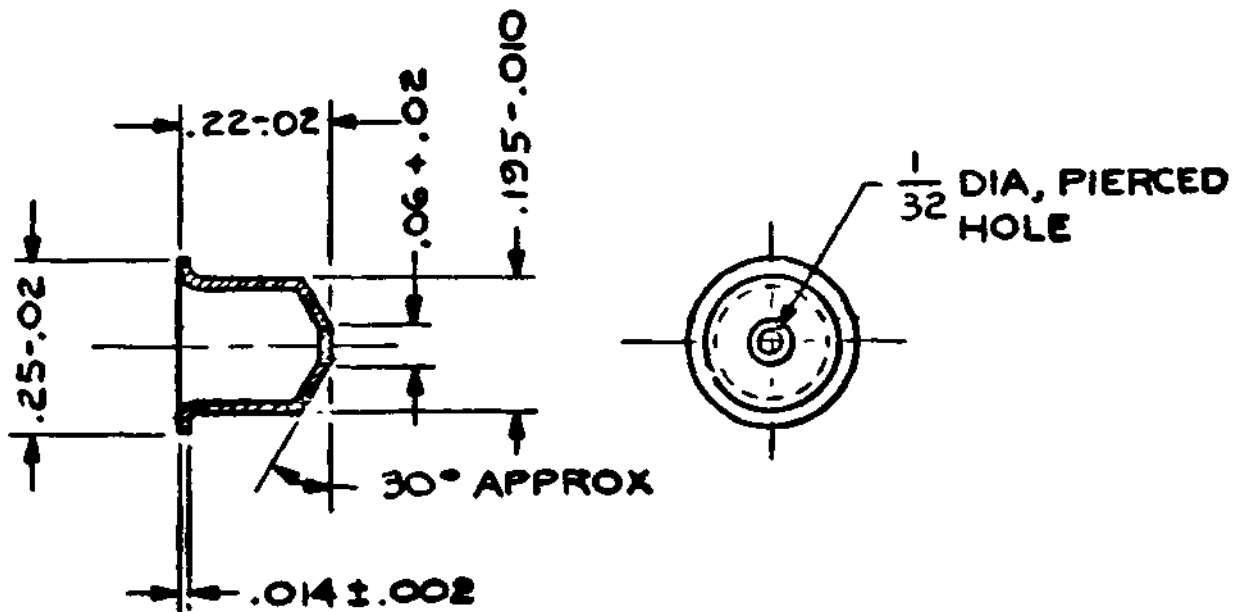

How to Build Flash/Stun Grenades

Part No. 8833717
SLEEVE
(Component of part
No. 8833721 M3A1 igniter)

Material: Kraft paper, Spec. UU - P - 268, type I, grade A or B
(60 lb. wt. advisory)

Material is spiral wound with polyvinyl acetate resin emulsion part No. 9347369 between layers or convolute wound with dextrin adhesive, spec. MIL - A -13374, class I between layers.

Notes: 1 - Spec. MIL - A - 2550 applies
2 - Snug slide fit on part No. 8833712, tube

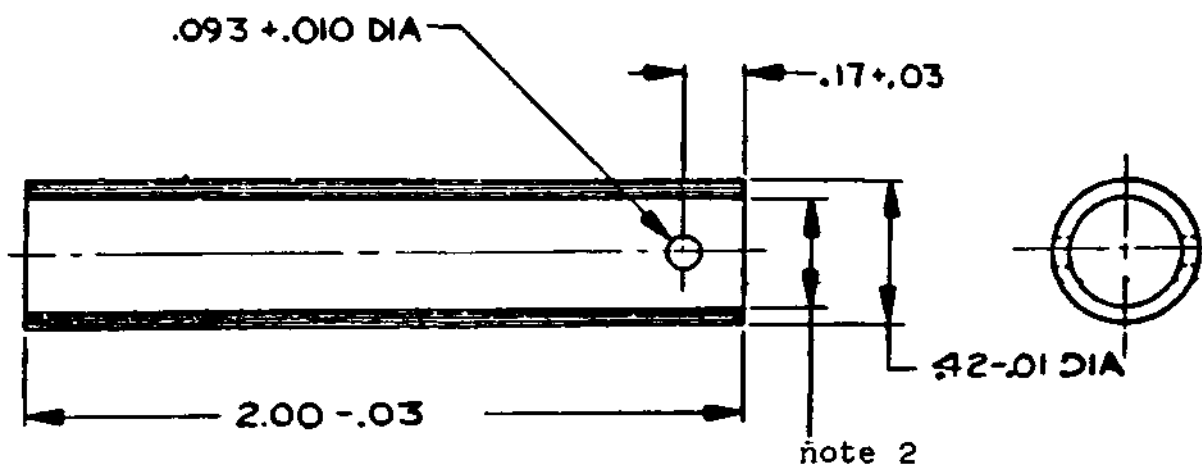

MI 16 Grenade Simulator

Part No. 8833718
CAP
(component of part
No. 8833722 M3A1 igniter)

Material: Plastic, molding, spec. L- P - 398, type III, class B, white opaque color

Notes:

- 1 - Spec MIL - A - 2550 applies
- 2 - $1\ 1/2^\circ$ max. draft permitted within inside and outside diameter tolerances
- 3 - Excess plastic flash to be removed
- 4 - Untoleranced dimensions need not be gauged.

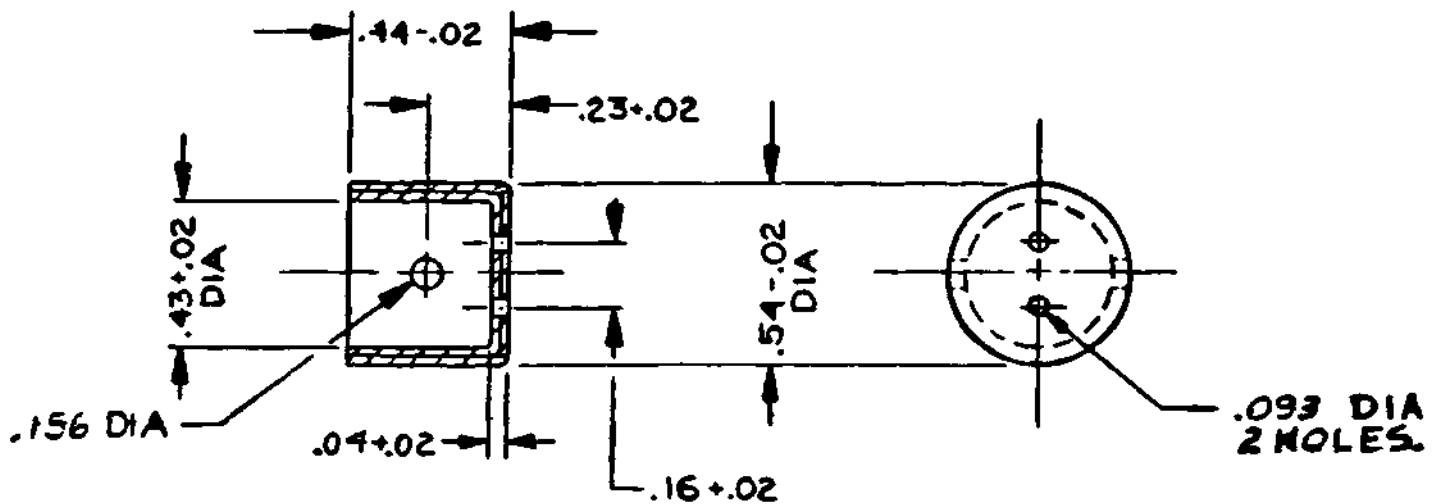

How to Build Flash/Stun Grenades

Part No. 8833719
IGNITER CHARGE WIRE ASSEMBLY
(component of part
No. 8833722 M3A1 igniter)

Material: Wire, steel, carbon, AISI No. 1010, annealed, gauge No. 23 (0.026 inch dia.), spec. QQ - W - 461, 4 1/2 inches before forming.

Notes:

- 1 - Spec. MIL - A - 2550 applies
- 2- After forming:
 - a - Degrease in 1-1-1 trichlorethane bath, spec. O - T - 620, type I
 - b - Apply thin coating of 7-15 grams orange shellac, spec. TT-S-271, type I, form a, grade A or B dissolved in 200 ml ethyl alcohol, spec MIL-E-463, grade 5, or spec O-E-760, grade I, class A
 - c - Allow to dry before coating with friction composition
- 3 - Coat minimum 3 spaces and maximum 5 spaces of wire with friction composition as follows:

Dissolve orange shellac, spec. TT-S-271, type I form a, grade A or B, 5.5±2.0 grams in ethyl alcohol, spec. O - E - 760, grade I, class A or spec. MIL - E - 463, grade 5-100 ml. add, phosphorus, red, spec, MIL - P - 670, - 1.5 gram/1 ml. solution

- 4 - Check that a minimum of 3 spaces of wire nearest to the cup are free of friction composition
- 5 - Allow friction composition on wire to dry
- 6 - Coat all 8 spaces of wire with nitrocellulose-acetone solution of the following composition:

	% by wt.
Cellulose nitrate-camphor binder, spec. MIL - B -10854	10 + 5
Acetone, spec. O - A - 51	90 - 5
- 7 - Prepare igniter composition

	%by wt
Potassium chlorate, spec. MIL - P 150, grade A, class 4	88.0 ±2.0
Charcoal, spec. JAN - C 178, class C	10.0 + 0.5
Dextrin, spec. MIL - D - 3994, technical	2.0+0.5

M116 Grenade Simulator

- 8 - Dampen ignition composition with water prior to charging into cup
- 9 - Charge approximately 0.041 gram igniter composition into cup
No. 8833716
- 10 - Apply approximately 140 Kg. total load to compress the charge
- 11 - Clean all loose particles of igniter mix from the lip, radius and up to 0.010 inch below the radius on the inside of the cup
- 12 - Assemble friction wire with the igniter cup
- 13 - Dry the assembly
- 14 - Apply a drop of nitrocellulose acetone solution (step 6) to the igniter charge to coat its surface
- 15 - Dry finished assembly $43 \pm 5^{\circ}\text{C}$. and 40% relative humidity for 48 hours minimum

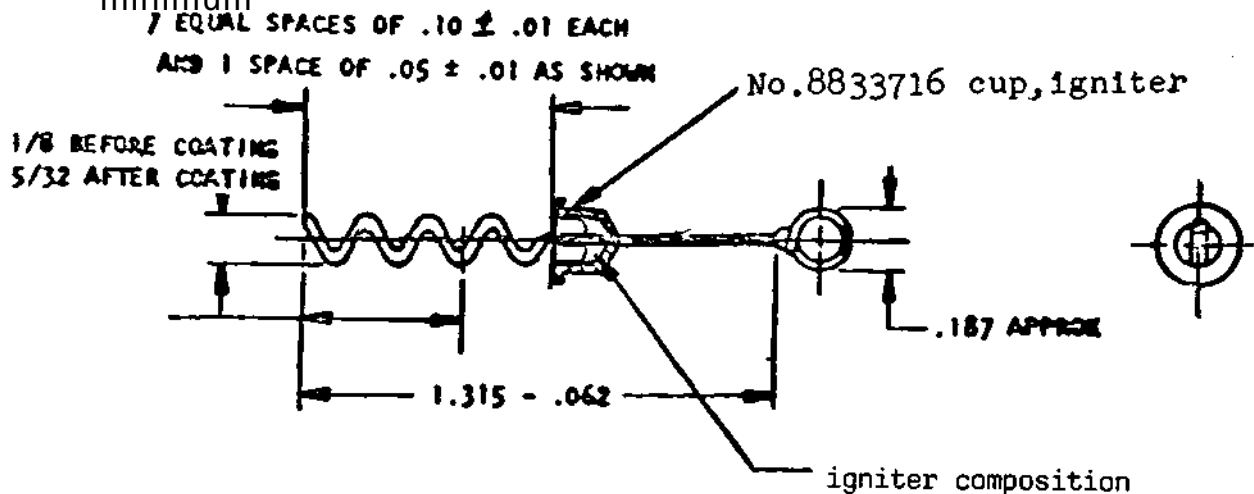

How to Build Flash/Stun Grenades

Part No. 8833721
IGNITER,
BLASTING FUZE,
FRICTION TYPE, M3A1 ASSEMBLY

Notes:

- 1 - Spec. MIL - A-2550 and MIL -1 - 12597 apply.
- 2 - Secure tube No. 8833712 within sleeve No. 8833717 with adhesive No. 92123301
- 3 - Assemble the winding pull cord No. 8833723 as shown.
- 4 - Prior to assembly of ferrule, tumble quantities of approximately 500 igniters for 20 ± 2 minutes minimum in a tumbler, then visually inspect 100% for evidence of ignition and discard all items which ignited.
- 5 - Dry complete assembly at $43 \pm 5^{\circ}\text{C}$. and 40% relative humidity max. for 48 hours minimum. Pack and seal in barrier bag material in accordance with drawing No. 8835012, while still warm for interplant shipment.

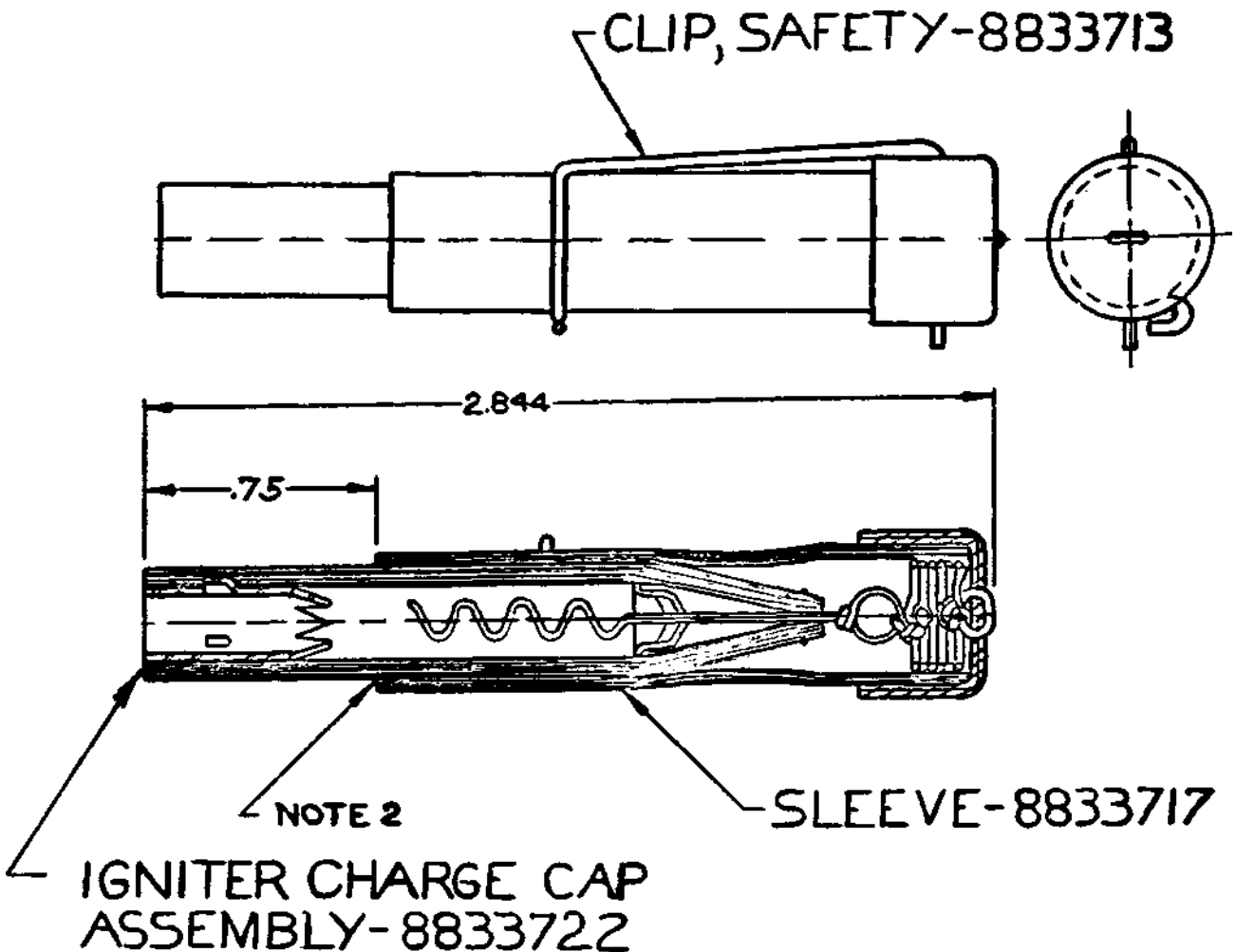

MI 16 Grenade Simulator

Part No. 8833722
IGNITER CHARGE
CAP ASSEMBLY M3A1

Notes:

- 1 - Spec. MIL - A - 2550 applies.
- 2 - Ferrule and igniter cup No. 8833716 to be securely held in place at assembly.
- 3 - Tie ends of pull cord together with double overhand knot (see illustration) to form a loop. Insert end of pull cord loop through loop in end of friction wire. Pass free end of pull cord through the loop of the cord, pull tightly to secure cord to friction wire. Assemble igniter sleeve to igniter tube from wire loop end. Thread loop of pull cord through one hole in top of plastic cap from inside of cap. Thread loop of pull cord back through second hole in cap from the outside of cap. Pass free end of loop over cap. Pull tightly to secure cord to the cap.
- 4 - After stapling, crimp staple and tube slightly so assembly will fit into sleeve No. 8833717.

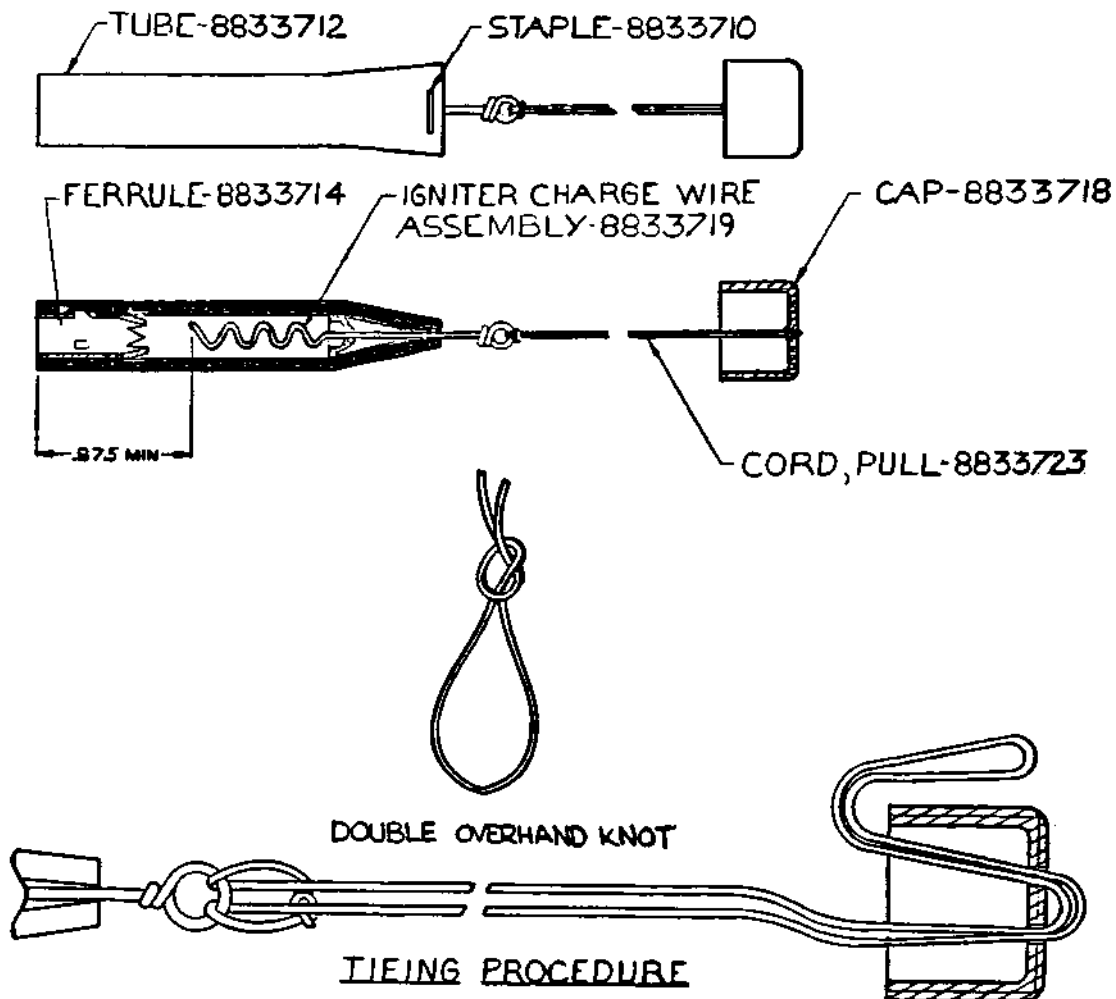

How to Build Flash/Stun Grenades

2 - Delay

The delay used in the simulator is a piece of time blasting fuse, approximately 3 inches long. This fuse transmits the flame from the igniter to the filler. The fuse is

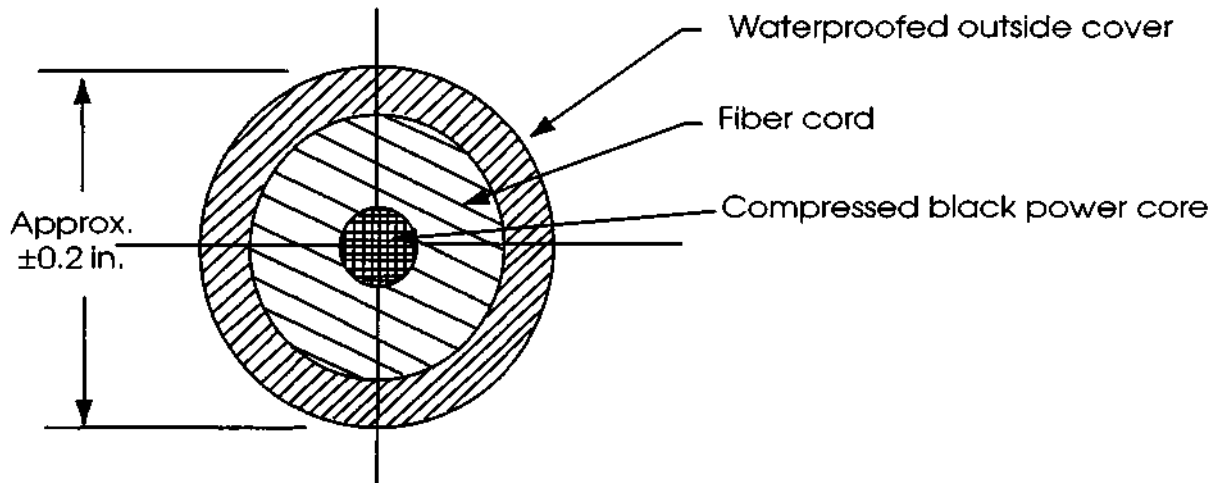

made in the form of a cord with the following cross-section.

Depending on the manufacturer, the outside cover may be a thin waterproof coating, with a woven cotton outside cover, a single layer of heavy plastic, or a tar impregnated textile, etc. The burning rate may vary from manufacturer to manufacturer, and even between lots, but is kept to 30-45 seconds/ft. Some kinds of fuse are marked on the outside for easy identification and to facilitate measuring off the required length. Since the fuse is used in a variety of commercial and military applications, such as mining, demolition, quarry and road building, etc. it must satisfy a number of safety requirements which do not necessarily apply to subject to this volume. A fuse used in a grenade simulator requires:

- a - a uniform and steady burning rate
- b - positive ignition by igniter flame
- c - positive initiation of the filler composition
- d - mechanical strength to withstand field handling
- e - waterproofing

The MI 16 simulator fuse is 3.0 inches long; after cutting to length, the fuse ends are dipped into a combustible sealant to prevent crumbling out of core material and to increase flame surface area.

3 - FILLER

A typical grenade simulator filler is of photoflash composition described in MIL - P - 466 and MIL - P - 48239 specifications listed in the section on materials.

MI 16 Grenade Simulator

The composition consists of:

Aluminum powder.....40%

Potassium perchlorate.....30%

Barium nitrate.....30%

**) This mix generates not only high temperatures and bright flash but also a respectable explosion.*

The granulation of the fuel and oxidizers is such that insures a maximum surface contact between the components. Also, the smaller the individual particles, the faster they burn, and the bigger the "Bang."

By nature the filler composition is a sensitive and dangerous pyrotechnic mix requiring utmost caution in preparation and handling. The manufacturing processes such as blending, screening, and loading are all remote controlled and follow safety precautions used with sensitive explosives. Typical safety procedures are listed under the appropriate section.

The photoflash formulations presently used by the various services are designed to comply with the requirements of the films used in night photography. The expedient flash grenade filler is not controlled by these requirements, hence the formulation may be different, most satisfactory for the purpose intended. The military photo flash must produce light of specific intensity and in a definite time interval corresponding to the open period of the camera shutter, and even in a predetermined direction. The expedient flash grenade mix, on the other hand is required to blind and stun the target for the few seconds needed by the thrower for other action.

The flash powder mixes may be divided roughly into 3 categories- those using Aluminum, Magnesium, or the mixture of both metals, as fuel. Each of these metals (mixes) has its advantages and disadvantages. Only those pertaining to the expedient devices will be discussed.

Aluminum - produces a hotter and brighter flame than Magnesium, the oxidizers may be perchlorates of sodium, potassium, barium, or strontium.

Magnesium - atomized material gives a shorter flash, mixes with nitrates produce lower intensity light than perchlorates increasing portion of Magnesium in the mix gives shorter and more powerful flash (60% Mg mix gives the maximum performance) material of less than 100 mesh is preferable to 325 mesh mixes with perchlorates although more effective, are more sensitive to impact and friction than mixes with sodium nitrate.

Magnesium- Aluminum alloy - this material gives performance somewhere between pure Aluminum and pure Magnesium mixes. The alloy mixes were used

How to Build Flash/Stun Grenades

mainly in the past because the alloys were brittle and easily pulverized. The development of atomizing of metals eliminates the need of these alloys.

The use of perchlorate as oxidizers is based on their better performance than nitrates. Perchlorates generate higher temperature and a more efficient burning of the metal powder, particularly Magnesium.

The flash filler output depend on the following factors:

- charge weight
- filler composition
- particle size
- charge geometry (diameter and form)
- igniter
- body (case) material

4- Body

A grenade simulator body is made from a piece of cardboard tube, three inches long, with two cardboard end caps. This material has been selected for the following reasons:

- a - adequate strength to initiate a satisfactory combustion of the filler, yet weak enough to open without absorbing too much energy from the burning filler
- b - no hard fragments to cause injury at the target
- c - availability and relatively low cost

Obviously other materials such as waterproofed textiles, or felts, flexible plastics, etc. could be used. However, at present, cardboard seems the optimum choice.

If soft materials are used for the body, then the filler must be compressed in a die, inside a suitable pouch, since the body material may not be able to withstand the compression force.

Chapter 2

Flash/Stun/Illuminating Grenades

This is the newest type of hand grenade. It is intended to neutralize the target temporarily yet rapidly by blinding. A conventional type incendiary grenade fuse ignites the filler which burns approximately 40 ± 10 milliseconds producing a powerful flash of about 5 million candelas intensity.

Because of the low level blast effect the grenade may be used in confined areas. It is intended for commando-type operations to capture prisoners, etc. Its size and form is similar to the illuminating type grenade.

Now that the grenade simulator construction is understood, let's review the flash-stungrenade.

It also consists of the four basic elements listed previously. However, since the intended use is different from the simulator, so are the details of each component.

1 - **Igniter, inexpensive:** is replaced by an M201 type fuse. This is a striker type, actuated only when the safety lever is forced away, after the grenade leaves the user's hand. It is of the mechanical type with almost 50 years of reliable service with very few minor modifications. It is the most used fuse in a variety of applications.

The material specifications are covered by over 25 MIL -specs. The equipment used is the same type as used for manufacture of small pyrotechnic devices. The final choice depends on the production volume requirements and availability of labor.

The M201 fuse is shown on the next page.

How to Build Flash/Stun Grenades

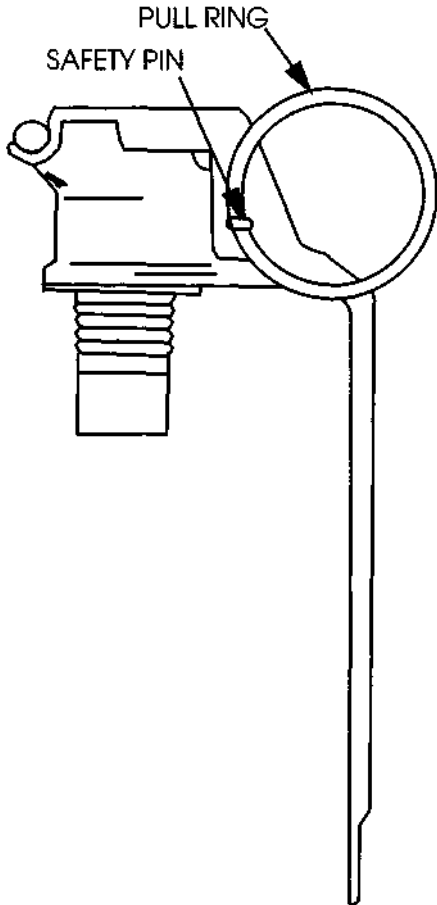

FUSE
M201A1
(MIL-F-51353)

Used as initiator in the following handgrenades:

Model No.	Type	Filler
AN-M14	thermite	
M6	riot control,	CN-DM
M7	riot control,	CN
M15	smoke,	WP
M16	smoke,	color
M18	smoke,	color

In 3 places stamp as indicated with letters and figures 0.09 high and 0.01 deep; alternative: mark with black stencil ink No. 37038 Spec. TT-1 - 1795, type I

Form safety pin to give withdrawal resistance of 10 lbs. minimum, 30 lbs. maximum

Configuration of pin to be approximately as shown, with pin legs equal in length and symmetrical within 0.06 inch.

Manufacturer's ID symbol, 2 digit year and single letter month of production as per MIL-STD- 1168

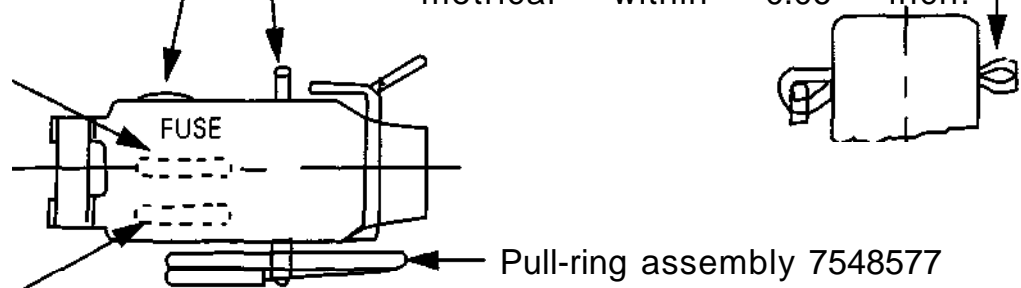

3 digit lot interfix and 3 digit lot sequence number and 1 letter lot suffix (if required) per MIL - STD - 1168

Flash/Stun/Illuminating Grenades

FUZE
M201A1
(MIL-F-51353)

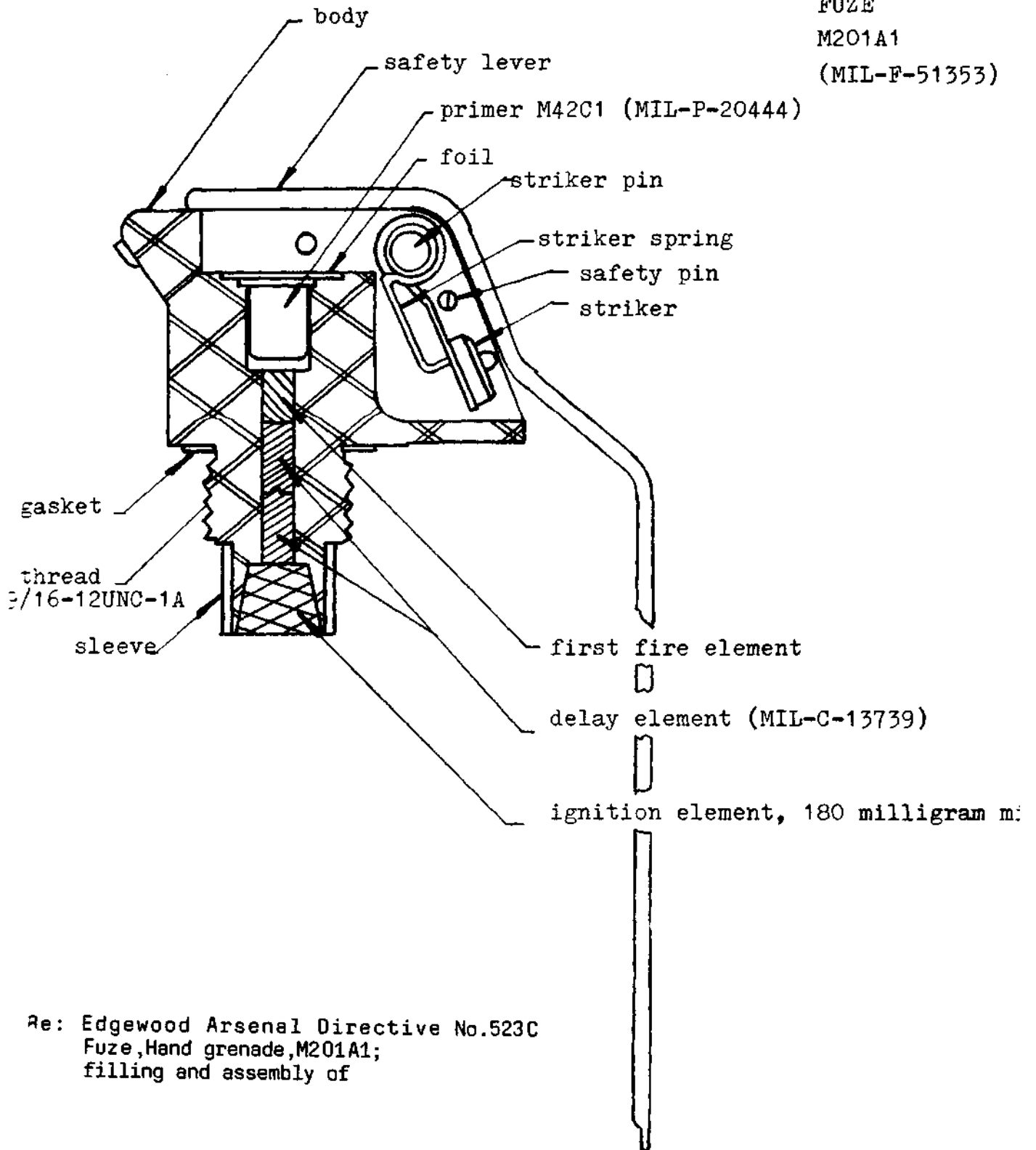

Re: Edgewood Arsenal Directive No.523C
Fuze, Hand grenade, M201A1;
filling and assembly of

TOP VIEW

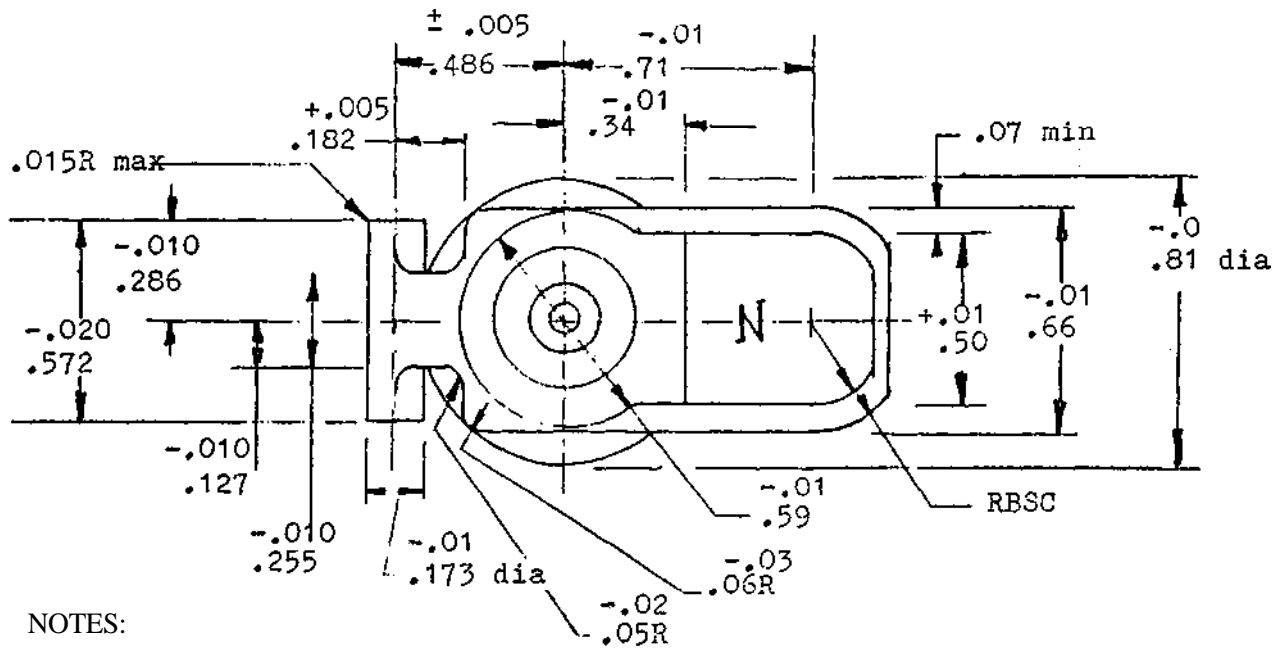

NOTES:

- 1 - the above dimensions also apply to FUZE M204 and FUZE M213
- 2 - "N" location for permitted cavity number 0.06 dia. max.
 manufacturer's symbol 0.1 dia.max.
 both raised 0.01 max.

FRONT VIEW

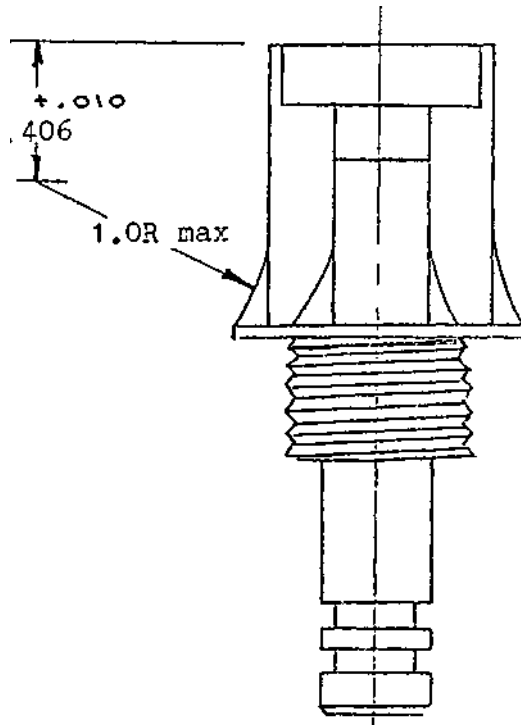

Flash/Stun/Illuminating Grenades

GRENADE, HAND
FUZE
BODY
SIDE VIEW

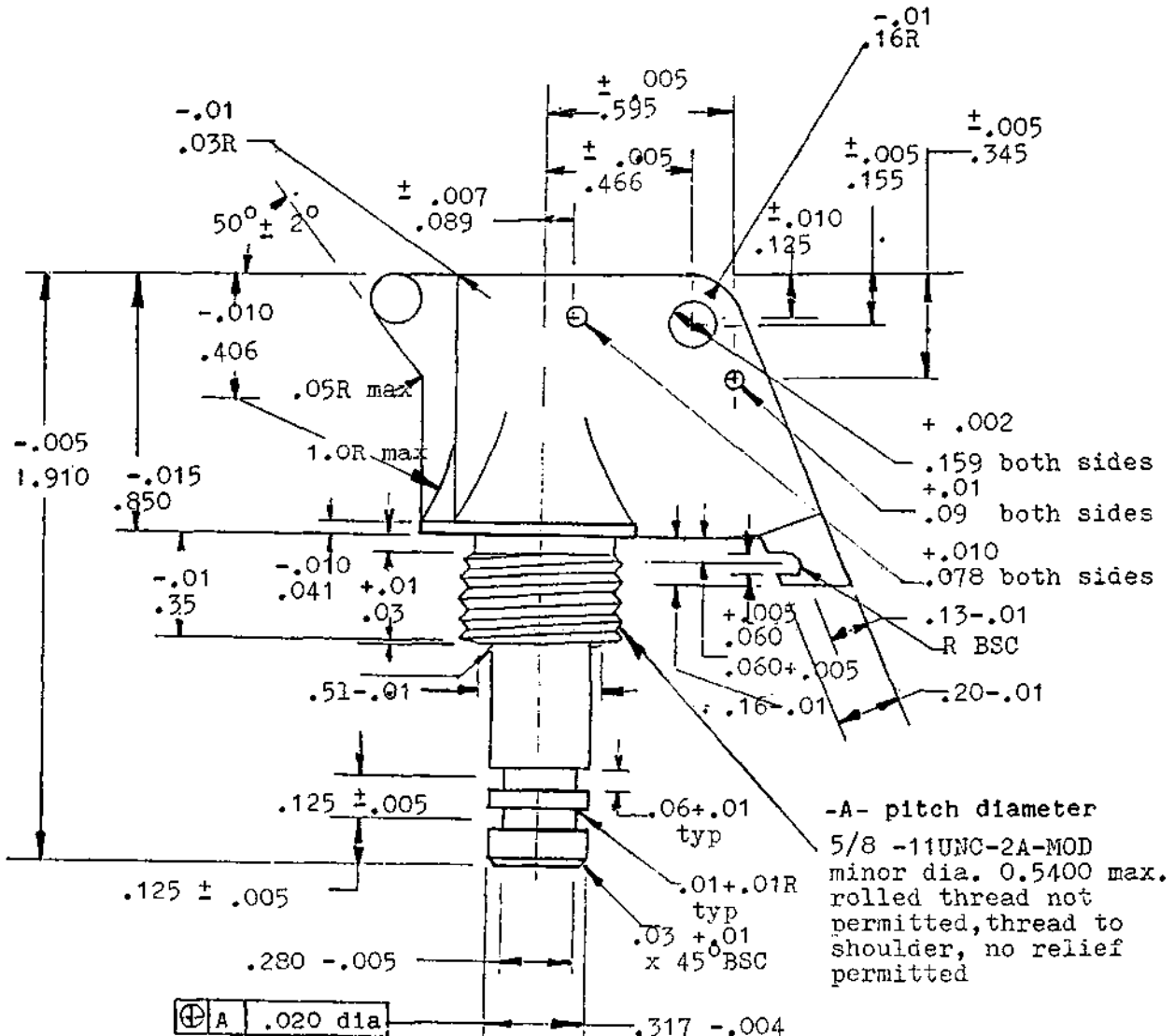

MATERIAL:

Zinc base alloy die casting AG- 40 A

aged 3-6 hours at 100 C or

5-10 hours at 85°C or

10-20 hours at 70°C

or AC 41 A , ASTM B86

FINISH :

type 7.3.1. or 6.1.2

COLOR :

olive drab No. X34087 or MIL -STD - 171

NOTE: MIL-A2550 apply

How to Build Flash/Stun Grenades

GRENADE, HAND
FUZE
BODY
SECTIONED VIEW

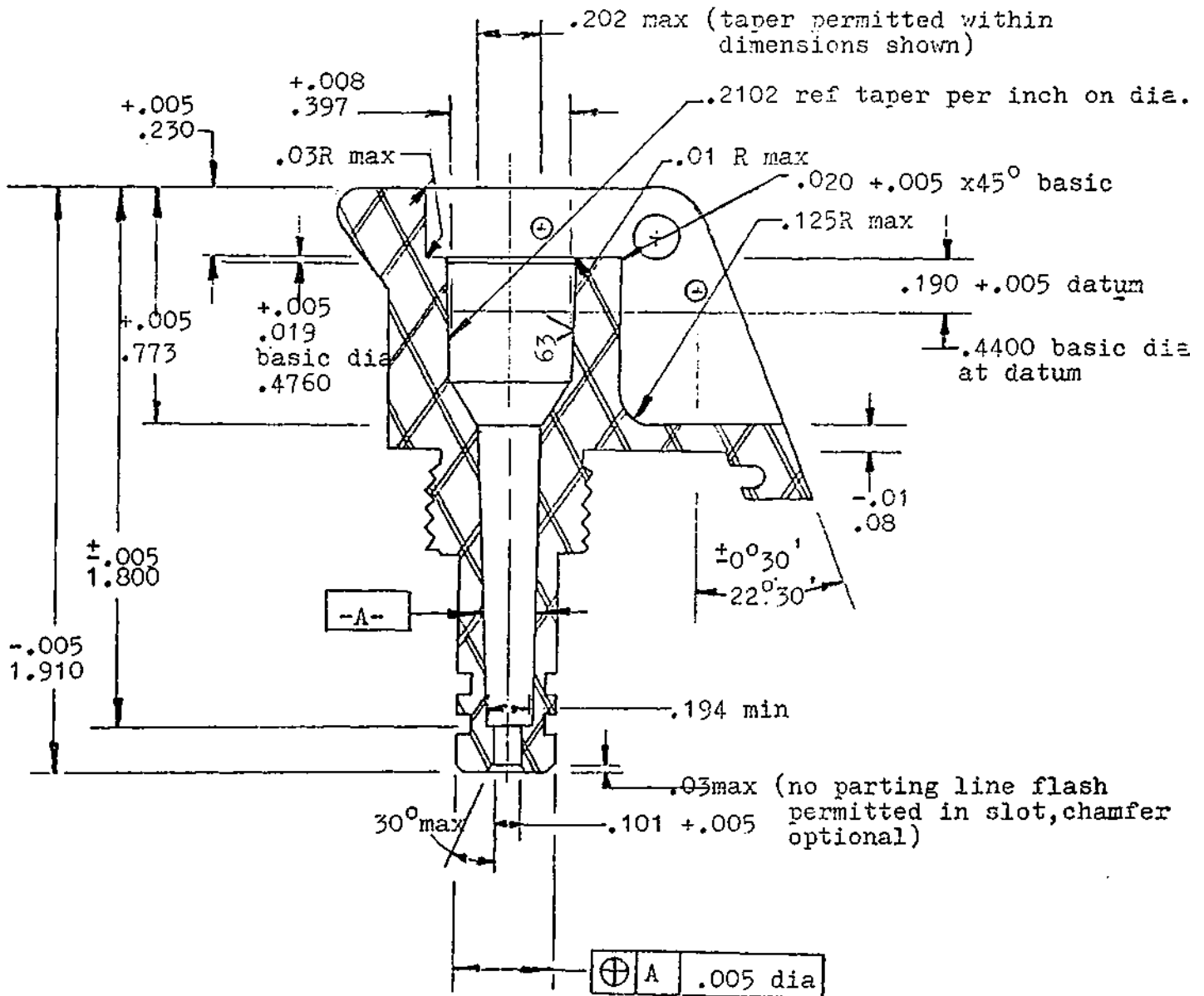

Note: the fuze bodies of the M201, M204 and M213 models vary basically only in the length and form of the stem below the threaded portion containing the delay component. The above dimensions show the fuze M213 version.

Flash/Stun/Illuminating Grenades

GRENADE, HAND
FUZE, M204 type
STRIKER

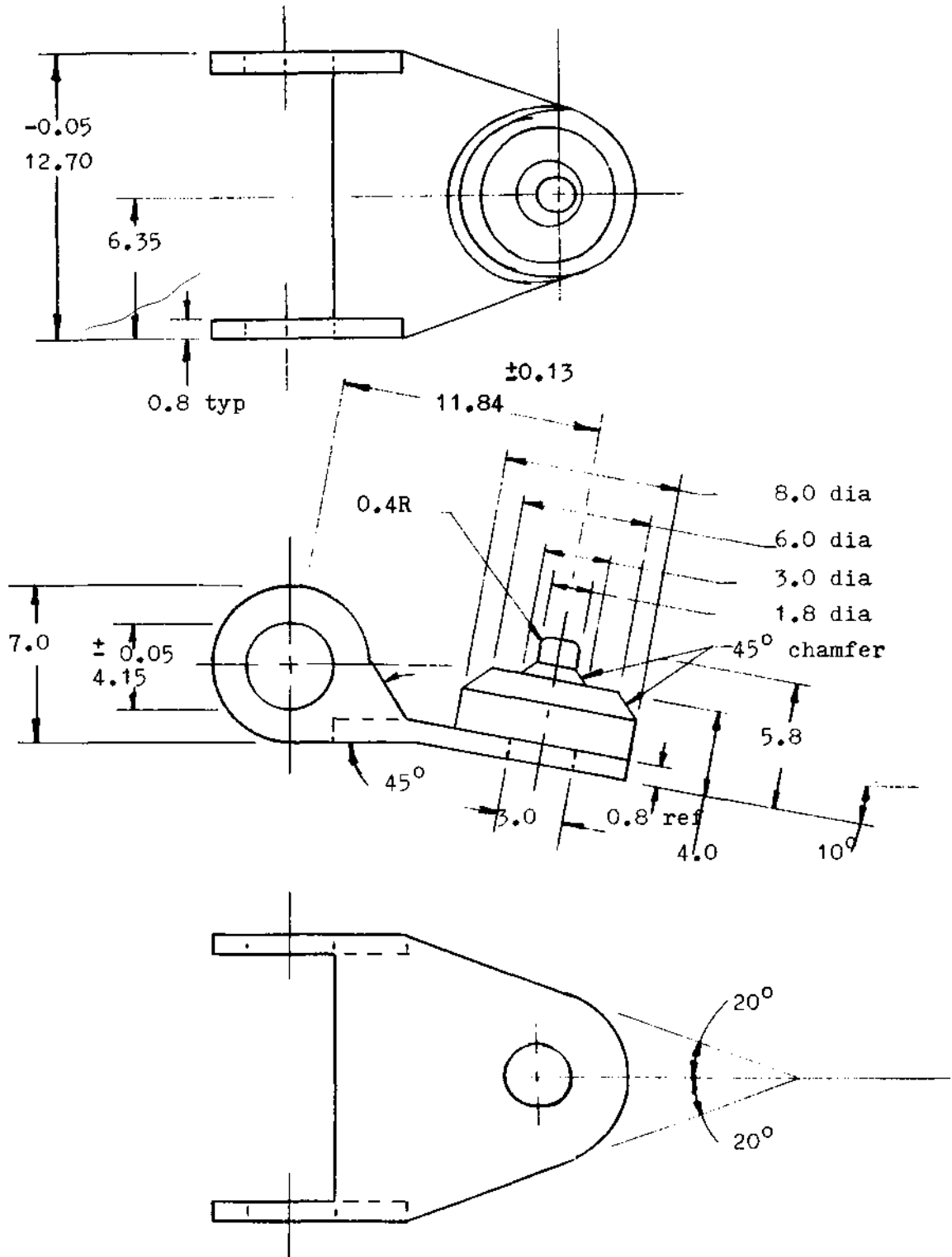

Note: all dimensions are in millimeters

How to Build Flash/Stun Grenades

GRENADA, HAND
FUZE, M204 type
STRIKER SPRING

Material: music wire
dia. 0.9 mm

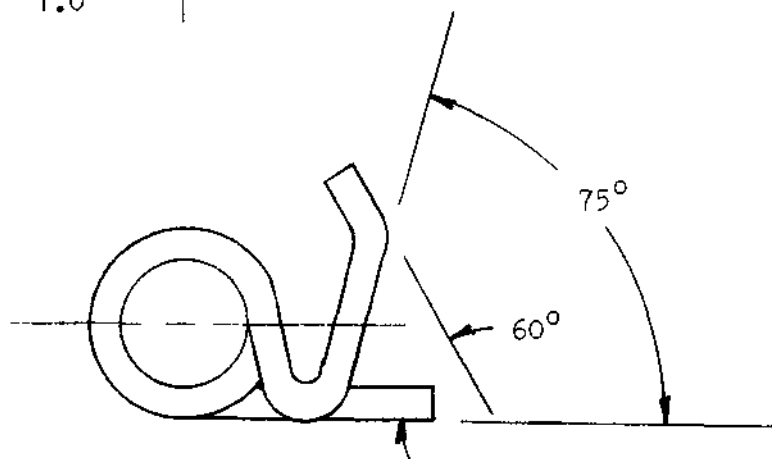
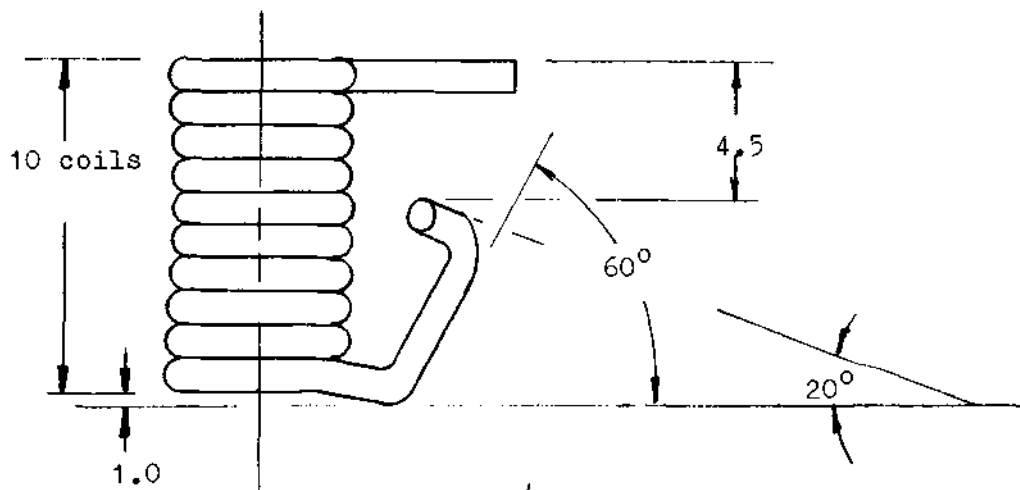
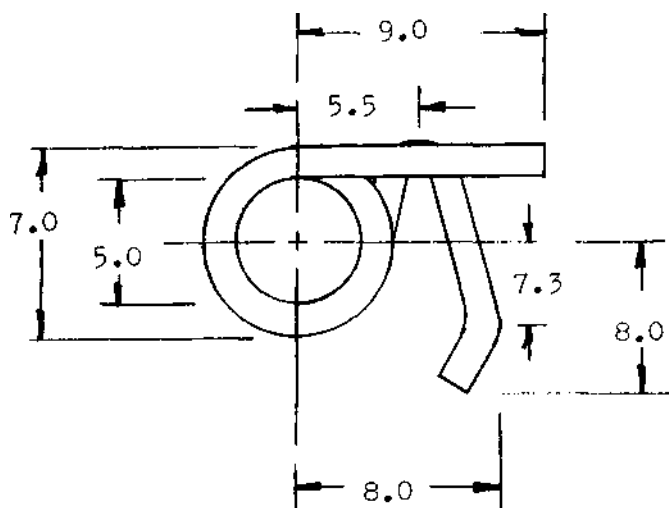

Note: all dimensions are in millimeters

Flash/Stun/Illuminating Grenades

GRENADE, HAND

FUZE

SAFETY PIN AND RING

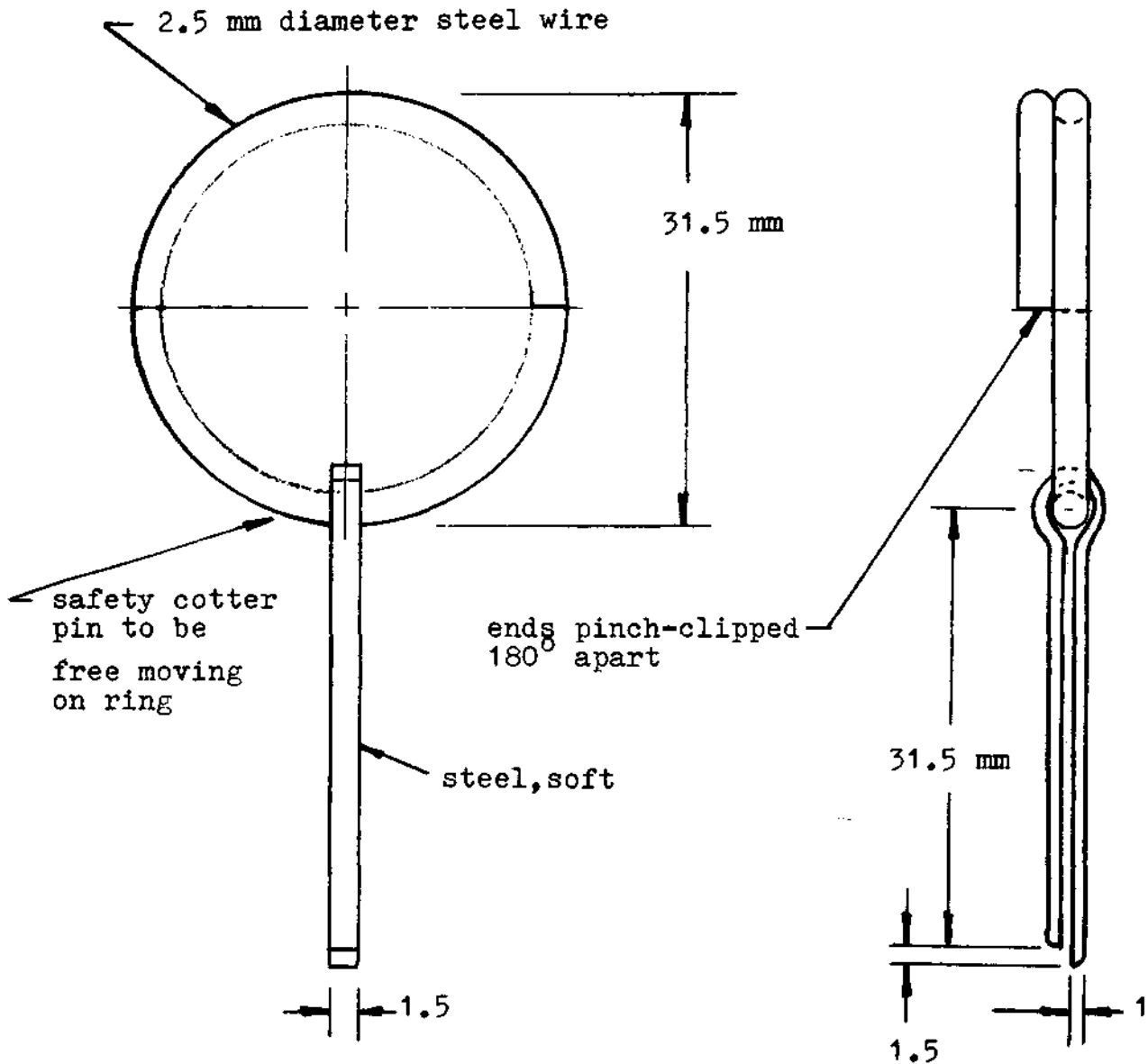

Note: all dimensions are in millimeters

How to Build Flash/Stun Grenades

GRENADE, HAND

FUZE, M204 type

STRIKER PIN

Material : steel,
cold rolled

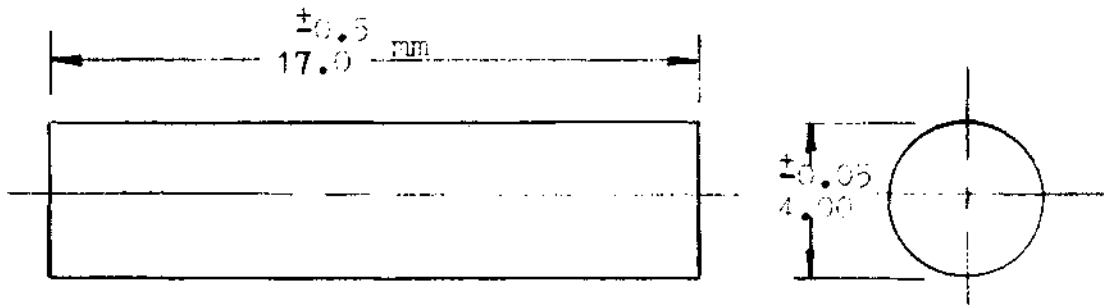

Note: all dimensions are in millimeters

Flash/Stun/Illuminating Grenades

GRENADA, HAND

FUZE ASSEMBLY

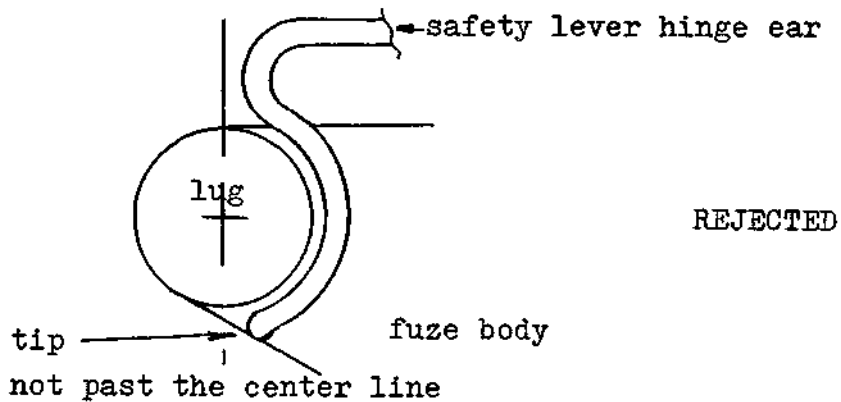
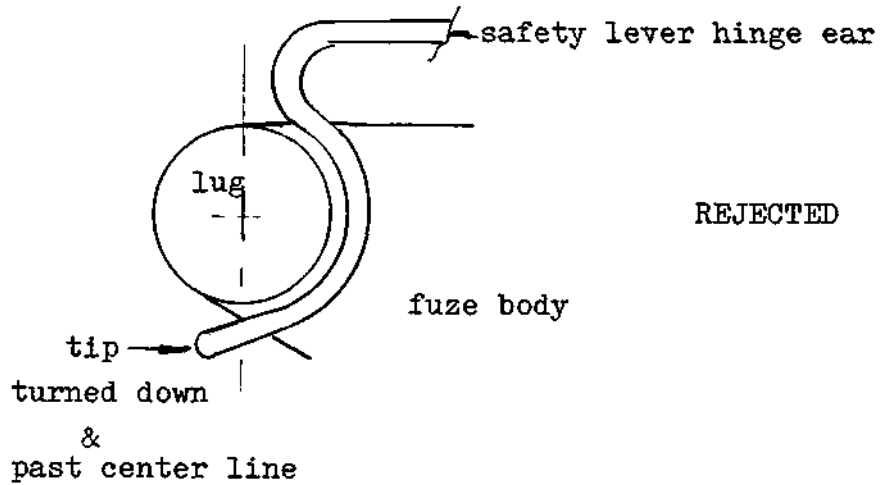
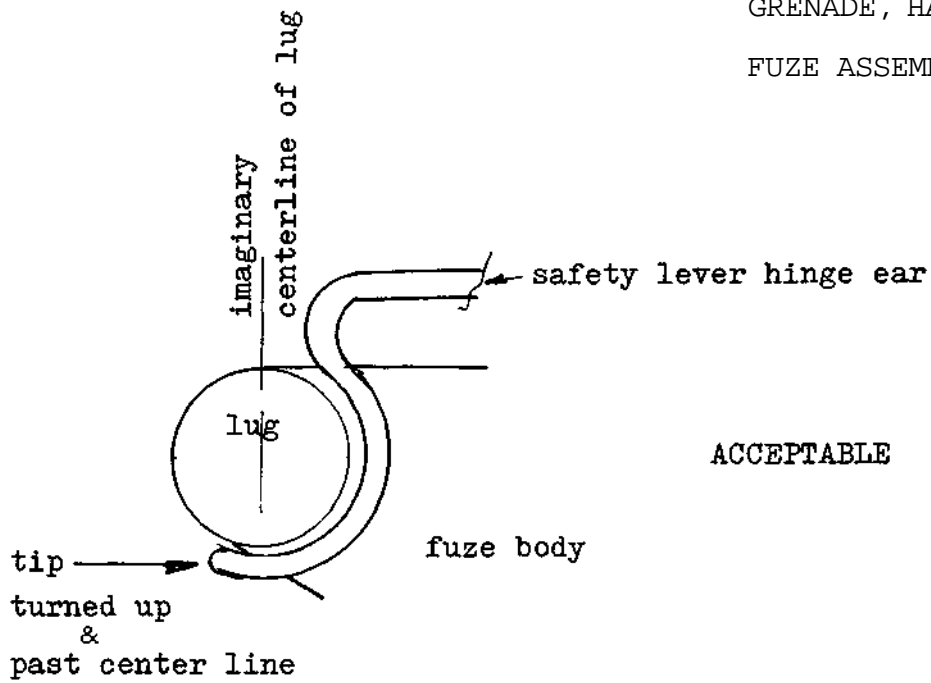

How to Build Flash/Stun Grenades

GRENADE, HAND FUSE ASSEMBLY OF PRIMER HOLDER ASSEMBLY AND FUZE BODY

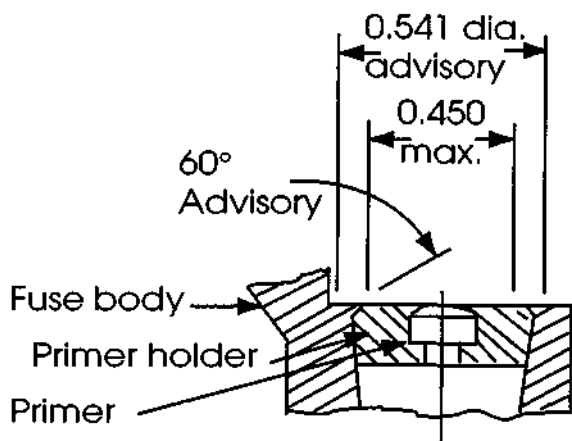

Joint and crimp marks coated with varnish, phenol-formaldehyde, specification MIL-V-13750, type III, grade A or B

- 1 - Secure body over primer holder with 360° crimp
- 2 - Secured primer holder to be 0 - 0/22 below flush with indicated body surface
- 3 - Push-out force for primer holder from body to be:
600 lbs. minimum
900 lbs. average minimum

Primer

The primer used in the fuse, hand grenade, M201 is a battery cup primer, similar to the conventional shotshell type primer. The main difference is in the priming mix composition. The military primers use Potassium Chlorate-Lead-Sulfonate type mix while the commercial substitutes use Lead Styphnate-Tetracene types. The M39 primer uses 26 milligram of mix while the M42 primer uses only 22 milligrams.

Primer
M39A1
M42

Specification
MIL-P-12951F
MIL-P-20444

Fiash/Stun/Illuminating Grenades

Material	Specification	% by weight
Silicon	MIL-S-230	25
Red Lead, Pb_3O_4	TT-R-191	50
Titanium	MIL-T- 13405	25
Graphite	MIL-G- 155	0.6 max
NC/camphor	MIL-B- 10854	1.8 max

Time delay, seconds		2	5	12
Material	Specification	% by weight		
Barium chromate	MIL-B-550A	60.0	60.0	60.0
Potassium perchlorate	MIL-P217	14.0	14.0	14.0
Zirconium-nickel alloy	MIL-Z- 11410	26.0	9± 2*	3+ 1 *
powdered type 1 (70/30%)				
Zirconium-nickel alloy	MIL-Z 11410	—	17± 2*	23± 1 *
Zirconium-nickel alloy	MIL-Z-11410	—	17± 2*	23± 1 *

*) Fuel ingredients may vary within tolerances to meet burning rate requirements

Ignition Mix

Material	Specification	% by weight
Iron Oxide, black	MIL-I- 275 TT-P-375)	
Titanium	MIL-T-13405	
Zirconium	MIL-Z-00399	

Total: 0.180gra

How to Build Flash/Stun Grenades

Re: drwg B143-8-2

2 - **Delay:** the simple piece of time fuse is replaced by a delay assembly similar to that of a high explosive grenade. In some instances the delay is replaced by an ejector-initiator which propels the filler composition (now in a separate container) out of the grenade.

3 - **Filler:** the photoflash composition of a simulator may be contained as a separate subassembly in one, or several individual units. Additional units (pellets or cartridges) of high explosive, illuminating, smoke generating, color marking, etc. may be included in the grenade. The combinations are many and are dictated by the buyer's (or user's) preferences.

4 - **Body:** now the simple cardboard tube becomes a plastic or thin metal container. The cardboard end cup is not suitable anymore since the fuse cannot be threaded into it. The whole assembly increases in size and weight.

Flash/Stun/Illuminating Grenades

An example of the latest state of the art flash-stun grenade, commercially available is the model 429 from Accuracy Systems, Inc. in Phoenix, Arizona 85032.

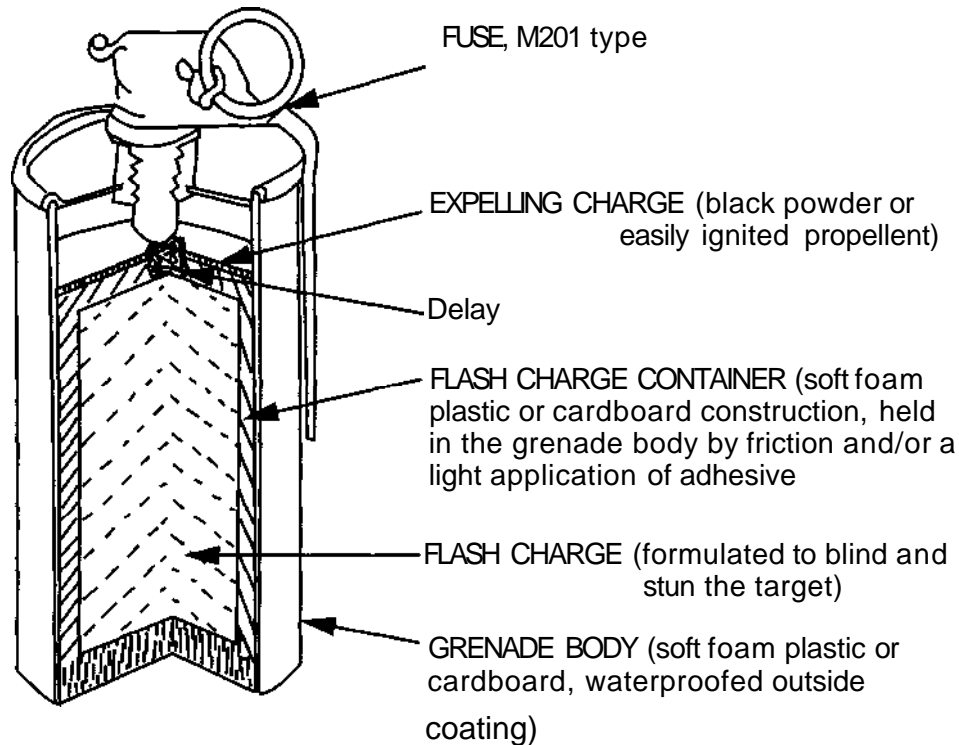

Note:

When above grenade is thrown, the safety lever is ejected away from the fuse by the striker spring. The striker is then free to fire the primer which in turn initiates the pyrotechnic system (igniter-expelling charge-delay-flash filler). This method gives the utmost safety to the user as well as prevents possibility of casualty inflicting fragments. The use of a separate flash charge container with a short delay sets off the flash charge only after ejection from the grenade body. Thus the fuse assembly and the grenade body will not become casualty causing fragment.

A possibility exists that the target will have the eyes closed, be turned away from the flash, or anticipate the flash and be on guard. Therefore, additional pyrotechnic devices may be incorporated into the grenade body such as:

- loud whistle to attract attention so that the face and eyes are in the direction of the flash
- Sparklers to draw attention and to confuse
- multiple smaller flash sub-containers
- multiple small firecrackers simulating firing of small arms
- combinations of above

However, further discussion on the variations and possibilities of the above combinations is not the subject of this volume.

How to Build Flash/Stun Grenades

DODIC #1330-G895

Grenade, Hand Illuminating Mk1
grenade weight: 285 grams

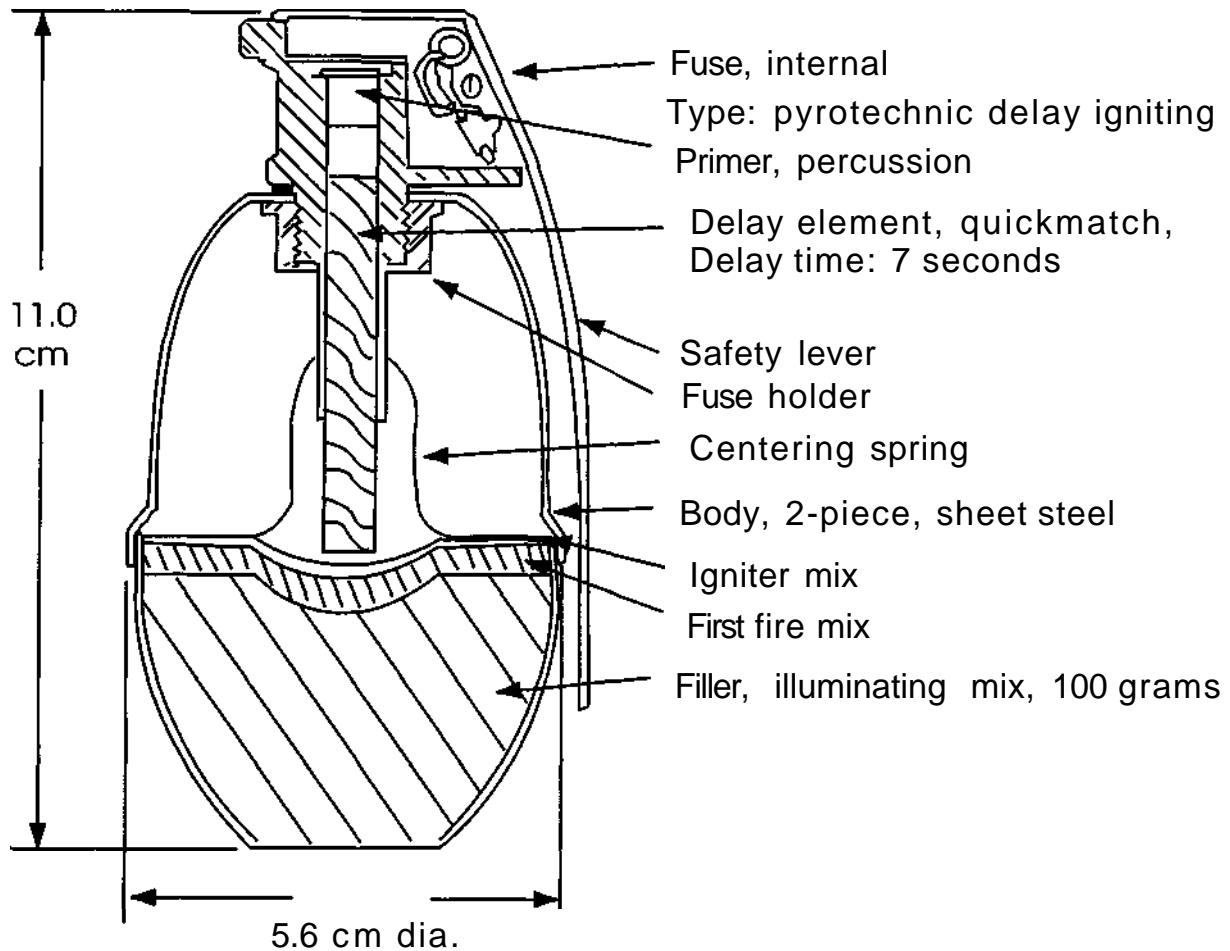

Operation:

- 1 - Upon leaving the hand, the safety lever is forced away from the body by the striker acting under the striker spring force; the striker is free to rotate on its axis and to strike the primer
- 2 - The primer ignites the quickmatch which in turn ignites the igniter mix; igniter mix ignites the first fire mix which in turn ignites the illuminating filler charge
- 3 - The gas pressure from burning filler separates the two parts of the body exposing the burning filler
- 4 - The filler burns 25 seconds with 55,000 candle-power, illuminating an area of 200 meters in diameter
- 5 - Because it produces hot flame, this grenade may be used as incendiary

Chapter 3

Expedient Flash Grenade

Once the construction of the flash grenade is understood, it is relatively simple to design an expedient model. The following is a step-by-step description of how to design and make a prototype expedient flash grenade using materials commonly available.

Again, start with the igniter. The simplest igniter is obviously a safety match. It is already in existence, most available, and inexpensive. Unfortunately, it has several serious drawbacks.

- a -the slightest wind will put it out almost instantly, unless carefully shielded
- b -in the darkness the open flame is visible further than the grenade can be thrown
- c -it requires time to strike the match, let the flame build up and to ignite the fuse
- d -ambient weather plays an important role in its reliability

Considering the reasons why, where, and when a grenade is used, it becomes clear why a reliable, quick and closed igniter is preferred. The following picture shows an expedient igniter which is essentially an M3A1 made from household components.

Studying the design one may come to the conclusion that this igniter is probably more complex than necessary. Before starting a simplification project it is in order to mention that various designs of simpler igniters were tested. All were based on the use of "strike anywhere" matches. Tests, using emery cloth as the friction surface were carried out with the following results:

- a -only the tip of the match will ignite by friction
- b -speed of the striking action is important; a slow pull across the friction surface will not ignite every time, hence the requirement for quick action is essential
- c -a definite force of about 3-5 lbs. must be applied to the tip during the striking action, otherwise it will not ignite

How to Build Flash/Stun Grenades

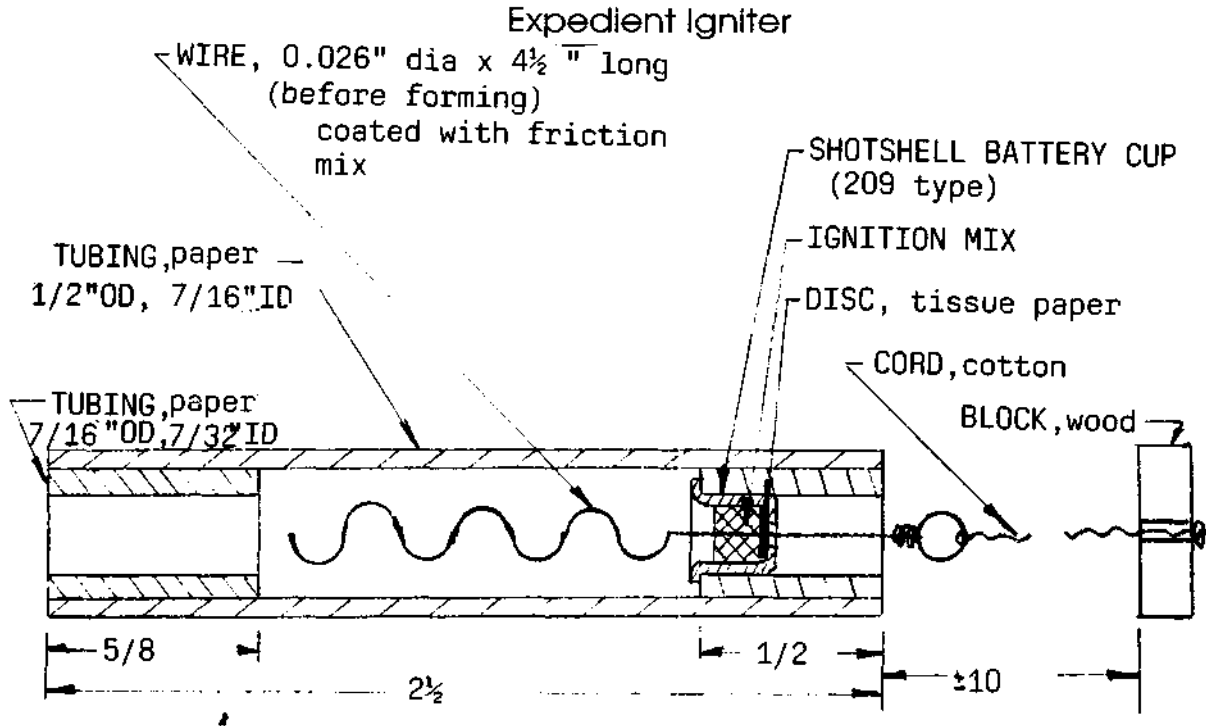

Based on these findings, various concepts were tried of which the gluing of 12 match tips to an axially pulled dowel appeared the most promising. Yet even this system did not perform well due to the need of force pushing the tip against the friction surface.

Following is a section through a typical "strike anywhere" match

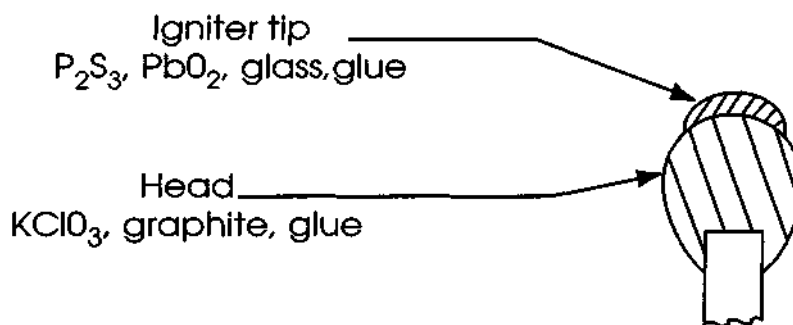

Note: trying to crush the match tip, even with a wooden peg on a smooth surface will almost invariably ignite them. Furthermore, both commercial safety fuses and expedient ones, using compressed black powder trains are very hard to start with matches. Procedures, such as slitting the fuse along the axis with the match insertion and taping etc. are required, prior to match ignition.

Expedient Flash Grenade

In conclusion, whoever designed the M3A1 friction pull igniter knew what he was doing, and reinventing the wheel is not called for. Furthermore, the quantities of phosphorus and potassium chlorate are so small that even 1/4 pound of each material (laboratory reagents come in 1 pound bottles) will last for many pieces.

Expedient Igniter

Equipment

- 1 - ruler, 6 inch
- 2 - scissors
- 3 - nail 16 penny, 2 each,
and 4 x 4 x 1/2 inch board
- 4 - soft egg holder
- 5 - tongue depressor, wood, small
- 6 - dowel, wood, $\frac{3}{16}$ " dia. x 6" long
- 7 - razor blade
- 8 - paper punch 1/4" diameter
- 9 - dowel, wood, 7/32 diameter x 6" long
- 10 - dowel, wood, 7/16" diameter x 6" long
- 11 - wooden paddle, 1/16" x 1/4" x 6" long
- 12 - bottle, approx. 5 ml capacity, covered
- 13 - cup, glass, approx. 10 ml capacity
- 14 - beer mug
- 15 - eye dropper
- 16 - pliers, long nose, 2 each
- 17 - balance, 0-250 gram capacity

Use

- measure component materials
- cut components
- to form igniter wire
- blender for igniter mix
- igniter mix loader into cup
- compressing tool for igniter mix
- cut cord
- cut foiling disc
- form inside tubing
- form outside tubing
- seating loaded battery cup in tube
- Phosphorus mix holder
- ignition mix preparation
- washing battery cups
- metering shellac-ethanol solution
- handling wire
- weigh component materials

Materials

- 1 - paper, 8 $\frac{1}{2}$ " x 11"
- 2 - tape, electric, plastic
- 3 - cord, cotton
- 4 - paper, tissue
- 5 - wire, copper or coated steel
- 6 - battery cup 209 type
- 7 - shellac
- 8 - ethanol, denatured
- 9 - potassium chlorate
- 10 - graphite
- 11 - dextrin or sugar
- 12 - phosphorus, red
- 13 - acetone
- 14 - adhesive
- 15 - cotton, absorbent
- 16 - dishwasher detergent
- 17 - tape, adhesive, plastic
- 18 - toothpick, wooden, flat

Typical home use

- stationery
- general electrical insulation
- general use of twine
- paper towel
- electric wiring, picture hanging, etc.
- used (fired) shotsheli
- glue and wood finish
- antiseptic from drugstore
- laboratory (see materials)
- pencil "lead"
- flour and water mix
- laboratory (see materials)
- nail polish remover
- paper glue or epoxy for general use
- medicine
- dish washing
- general use
- dental hygiene (???? Martini maybe!)

How to Build Flash/Stun Grenades

Safety precautions:

See chapter 6

Procedures:

Body

- 1 - from a sheet of stationery paper cut a strip 3 inches by $8\frac{1}{2}$ inches long
- 2 - on a $\frac{7}{16}$ diameter dowel, roll a paper strip into a tight tube
- 3 - fasten the outside of the tube with a 12 inch strip of electrical tape; winding the tape at a 60° angle to the tube axis, with overlapping seams.
- 4 - slide the finished tube off the dowel; application of a light coat of lubricant to the dowel prior to paper rolling will facilitate the tube removal
- 5 - trim the tube ends with a razor blade or scissors to the required length
- 6 - from a sheet of stationery paper cut a strip $1\frac{1}{8}$ inch wide by $8\frac{1}{2}$ inches long
- 7 - on a $\frac{7}{32}$ inch diameter dowel roll the strip into a tight tube
- 8 - fasten the tube outside with a piece of electric or adhesive tape to prevent the tube from unrolling
- 9 - remove the tube from dowel and cut it into $\frac{1}{2}$ inch and $\frac{5}{8}$ inch long pieces
- 10 - apply adhesive to the $\frac{1}{2}$ inch long tube and push it inside the larger tube from step 5, flush with one end
- 11 - save the $\frac{5}{8}$ inch long tube for later

Igniter wire

- 12 - cut a piece 4 inches long of wire and shape it, using the board and nail (or long nose pair of pliers) into the form shown on sketch. The best expedient wire came from the spiral holding together a pad of school paper (in the supermarket stationery section)
- 13 - place a small quantity (about $\frac{1}{2}$ teaspoon) of red phosphorus into a small glass bottle (ampule), about $\frac{1}{2}$ inch diameter x $1\frac{1}{2}$ inch long (with stopper)
- 14 - add gradually drops of shellac-ethanol solution and blend with the $\frac{1}{4}$ inch diameter dowel. Note: polyurethane wood finish was used in some tests; its advantage was instant availability and good performance. However, it must be kept tightly closed to prevent drying out.
- 15 - dip the formed wire into the phosphorus mix so that all bends of wire are coated, but not the straight portion
- 16 - place the coated wire, bare ends in, into a low cup and allow to dry 24 hours at ambient temperature
- 17 - inspect the wire and clean any mix adhering to the straight portion of wire with cotton swab dipped in acetone
- 18 - dip the coated end of wire into the shellac-ethanol solution
- 19 - dry the wire 24 hours at ambient temperature
- 20 - store wire in a closed container (a flat cardboard box 4" x 6" x 1" deep with a cotton pad inside makes a good intermediate storage box)

Expedient Flash Grenade

Cup and ignition mix

- 21 - a battery cup recovered from a fired shotshell primer must be washed and dried prior to use. A beer mug 1/3 full of cups, 1 teaspoon of dish washer detergent and 1/2 full of hot water works quite well. Cover the mug with palm of your hand while shaking the mug with the other hand for a few minutes. Rinse the cups thoroughly with hot water and dry in a pan on stove. Although any battery cup works, the ones with small flash holes are preferred. Tests were run using the #209 Winchester primer battery cups which have larger holes, yet worked well.
- 22 - with a No. 5 leather punch blank out discs from a sheet of stationery paper. If a punch is not available, use a small square 1/4 x 1/4 inch, cut with scissors.
- 23 - seat the paper discs (squares) into the bottom of the battery cup to cover the flash hole and to prevent the ignition mix from spilling out; an 8-penny finishing nail works well
- 24 - for a good measure drop a shellac-ethanol solution onto the paper disc and allow to dry overnight; an eye dropper produces a small and uniform drop (wash the eye dropper with hot water after use)
- 25 - place the required quantity of Potassium chlorate into a small glass container (soft-boiled egg holder, one shot whiskey glass, etc.)
- 26 - prepare a few milliliters of sugar solution in hot water
- 27 - add a few drops of this solution to the pot
- 28 - add the required quantity of charcoal
- 29 - with the small wooden paddle blend the mix until uniformly mixed throughout
- 30 - with a flat wooden toothpick charge the mix into the battery cup
- 31 - with the $\frac{3}{16}$ inch diameter dowel compress the charge ("two finger tight")
- 32 - push the bare end of the igniter wire through the mix in the cup and out of the flash hole, so that only about 1/16 inch of the bare wire protrudes from the mix. Be sure that the phosphorus coated section of wire is NOT IN CONTACT with the chlorate mix
- 33 - wipe the end of the protruding wire and the cup rim clean so that no chlorate mix smears remain
- 34 - with two pairs of long-nosed pliers bend and twist the bare wire into a loop of less than 1/4 inch diameter (so it will pass through the hole in the small diameter paper tube)
- 35 - inspect the cup-wire assembly so that there is no contact between the chlorate and phosphorus mixes
- 36 - place the cup-wire assembly to dry 24 hours at ambient temperature (or oven at $\pm 45^{\circ}$ C)
- 37 - place a drop of shellac-ethanol solution onto the dry chlorate mix in the cup
- 38 - dry the cup-wire assembly 24 hours at ambient temperature

How to Build Flash/Stun Grenades

Assembly

- 39 - holding the coated end of wire with two fingers, insert the assembly, loop first, into the open end of the body (tube)
- 40- with a wooden paddle push the cup gently until its rim rests on the small diameter tube. DO NOT pull the assembly by the wire loop
- 41 - soak a small piece of cotton in the adhesive and push it gently into the small tube open end (from which the wire loop protrudes). The wire and the body may be held in one hand during this operation to prevent movement of the cup-wire assembly. DO NOT force the cotton too far as its purpose is only to prevent the ignition flame from flashing through the flash hole
- 42 - coat the $\frac{5}{8}$ inch long piece of the small diameter tube (from step 9) with adhesive and push it into the open end of the body
- 43 -dry the assembled igniter 24 hours at ambient temperature
- 44 - wrap the wire end of igniter with a 4 inch piece of electric tape to close the possible flame passage and to make this end waterproof
- 45 - push a piece of cotton twine through the wooden bead (block) and through the wire loop; tie both ends securely

The assembled igniter is ready for the grenade assembly.

Notes:

- 1 - The description appears long and tedious, but making 10 or more pieces at one time speeds the production considerably
- 2 - keep the flash hole in the cup as small as possible, just enough to go through with the bare wire
- 3 - seal all possible passages for the flame leaking back after the wire
- 4 - other materials were used to make the body (metal pipe, plastic tubing, etc.) none worked well since they all soak up the heat generated by the ignition and would not work reliably neither with the military, nor with the commercial fuses. The rolled paper body works well even at -25°C, is waterproof and quite strong
- 5 - the above process description and equipment are based on approximately 10-12 piece lots sizes, adequate for basic test study

Expedient Delay

- The availability of commercial safety fuse obviously solves many problems.
- The burning rate will be quite consistent (2 1/2 seconds/inch for some types)
 - fuse may be bent without affecting performance (see grenade simulator drawing)
 - a 10 foot coil of safety fuse provides 35-40 grenade delays
 - availability of fuse eliminates additional work

Therefore, whenever possible use ready made safety fuse. If the commercial fuse is not available, the delay element may be prepared by the following method:

Expedient Flash Grenade

Equipment	Use
1- balance, 10 gram capacity	weighing materials
2- funnel, small, paper	transfer material to straw
3- teaspoon, nonsparking, small	material handling
4- razor blade	cut straw
5- ruler, 6 inch length	measure straw
6- stop watch	check burning rate
7- board, wood, 2 inch wide x 6 inch long, 2 ea.	straw burning stand
8- bench vise	delay - igniter test fixture
9- non-sparking metallic die, $1\frac{1}{2}$ inch OD, a hole drilled and reamed through to allow a sliding fit (smooth, yet not loose) for the plastic straw. The die is made in several 1 inch long sections, fitting together, or held in a common holder, to allow making delays of various length	
10- punch, non-sparking (brass or stainless steel), having the same Outside Diameter (OD) as the straw inside. Punch is to be 1 $\frac{1}{2}$ inches longer than the assembled die column. Punch is used to compress the black powder delay.	
11- punch, non-sparking (brass or stainless) with OD allowing sliding fit inside the die hole. Punch to be 1- $\frac{1}{2}$ - 2 inches longer than assembled die column. Punch is used to push out assembled delay from die.	
12 - plug, non-sparking, OD to sliding fit inside die hole, $\frac{1}{4}$ inch long. Used as base for delay column during delay assembly and compression.	
13 - press, small arbor type, or drill press; to compact the black powder	
14 - weight, 10-15 lbs. on a hook; acting on the press handle to assure a uniform force on black powder column.	

Materials

- 1 - plastic straw
- 2 - black powder, FFFG size
- 3 - wooden matches
- 4 - silicone plastic sealant (tube)

Safety precautions

See chapter 6 for safety procedures

Procedures

- 1 - insert the plastic straw (clean and inspected to be free of defects) into the assembled die column
- 2 - cut off the straw flush with die top

How to Build Flash/Stun Grenades

- 3 - through the paper funnel feed a small predetermined quantity of black powder into the die
- 4 - insert the compression punch
- 5 - lower the press punch and compress the first increment
- 6 - repeat operations 3 through 5 until the delay is full. Note: to facilitate the work, pre-weigh powder charges into several small paper cups; the punch and die may be aligned in the press and the punch clamped onto the press ram, the use of pre-pelletized powder increments is also beneficial.
- 7 - push the complete delay out of the die, using the ejection punch
- 8 - apply a small drop of sealant on the exposed ends of the powder column
- 9 - dry assembled delay until sealant is dried (time depends on the type of sealant used)
- 10 - the delay element should have a uniform burning rate of 3 seconds per inch, and an overall length of 3 inches
- 11 - the delay is tested by laying it between two wooden boards and applying a burning match to one end of the delay. Record the average burning time and the shortest individual time of at least 10 samples. Varying the individual increment size and the compression force will affect the burning rate.
- 12 - after a delay has been developed which is about 3 inches long and burns uniformly for about 8 seconds, retest such delay at assembly with the expedient igniter. Note: cut one end of the delay at 45° angle, push this end into the igniter until it touches the wire, then pull the delay back about 1/8 inch. With a 4 inch strip of electric tape secure the delay to the igniter body and close the body opening.
- 13 - clamp the delay-igniter assembly in vise
- 14 - on a strip of paper, at the exit end of the delay, put a small quantity of black powder (on knife tip) so as to be in contact with the fuse end
- 15 - measure the time interval between jerking the pull cord and the "puff" of the powder on paper. A repeated time interval of no less than six seconds, and no more than 10 seconds is most satisfactory for the expedient use.

Regardless of the materials and the procedures used; once a satisfactory (safe and positive) process is arrived at, DO NOT change the specifications or the procedures.

Expedient Delay Protector Assembly

Equipment:

- 1 - dowel, wooden, 5/8 inch diameter x 6 inch long, for winding protector tube

Expedient Flash Grenade

- 2 - ruler, 6 inch
- 3 - scissors

Materials:

- 1 - paper, 8¹/₂x 11 inch
- 2 - tape, adhesive, plastic (Scotch tape) or paper (masking tape)
- 3 - adhesive, paper glue
- 4 - inert filler (Zonolite, dry sand, etc.)
- 5 - paper disc, 1/4 inch ID x ³/₄ inch OD
- 6 - expedient igniter-delay assembly

Safety precautions:
See chapter 6

Assembly Procedure:

- 1 - roll the tube of delay protector in a manner similar to that used for igniter body tube preparation
- 2 - apply adhesive to the igniter tube and slide the igniter-delay assembly into the protector tube, flush with the upper end as per grenade assembly drawing
- 3 - fill the inverted protector tube, around the delay, with the inert material, to the edge of the protector tube.
- 4 - seat the paper disc over the delay and into the protector tube
- 5 - apply adhesive around the inside and outside diameters of the disc to seal and secure the delay and the protector tube
- 6 - dry the assembly 24 hours in ambient air
- 7 - inspect the assembly visually, exposed end of delay to be sealed with thin film of adhesive and to be free from crushed black powder grains

Grenade Body

The drawback of the straw delay is its inability to bend without damage to the black powder core. A flash grenade with this type delay cannot use the construction and form of a grenade simulator like the MI 16.

To be protected from physical damage, the delay and the igniter should be placed inside a hard cardboard or plastic tubing. A typical design of an expedient flash grenade is shown on the next page.

A suitable grenade body can be made from a cardboard tube of approximately 1 1/2 inch diameter and about 4-5 inches long. Such tube is available in the core of toilet paper rolls, kitchen towel paper rolls, etc. It can also be made by rolling a strip of file folder (office paper) on a mandrel. The tube outside should be reinforced and waterproofed by overlapping layers of electric insulation tape, plastic adhesive tape, etc.

How to Build Flash/Stun Grenades

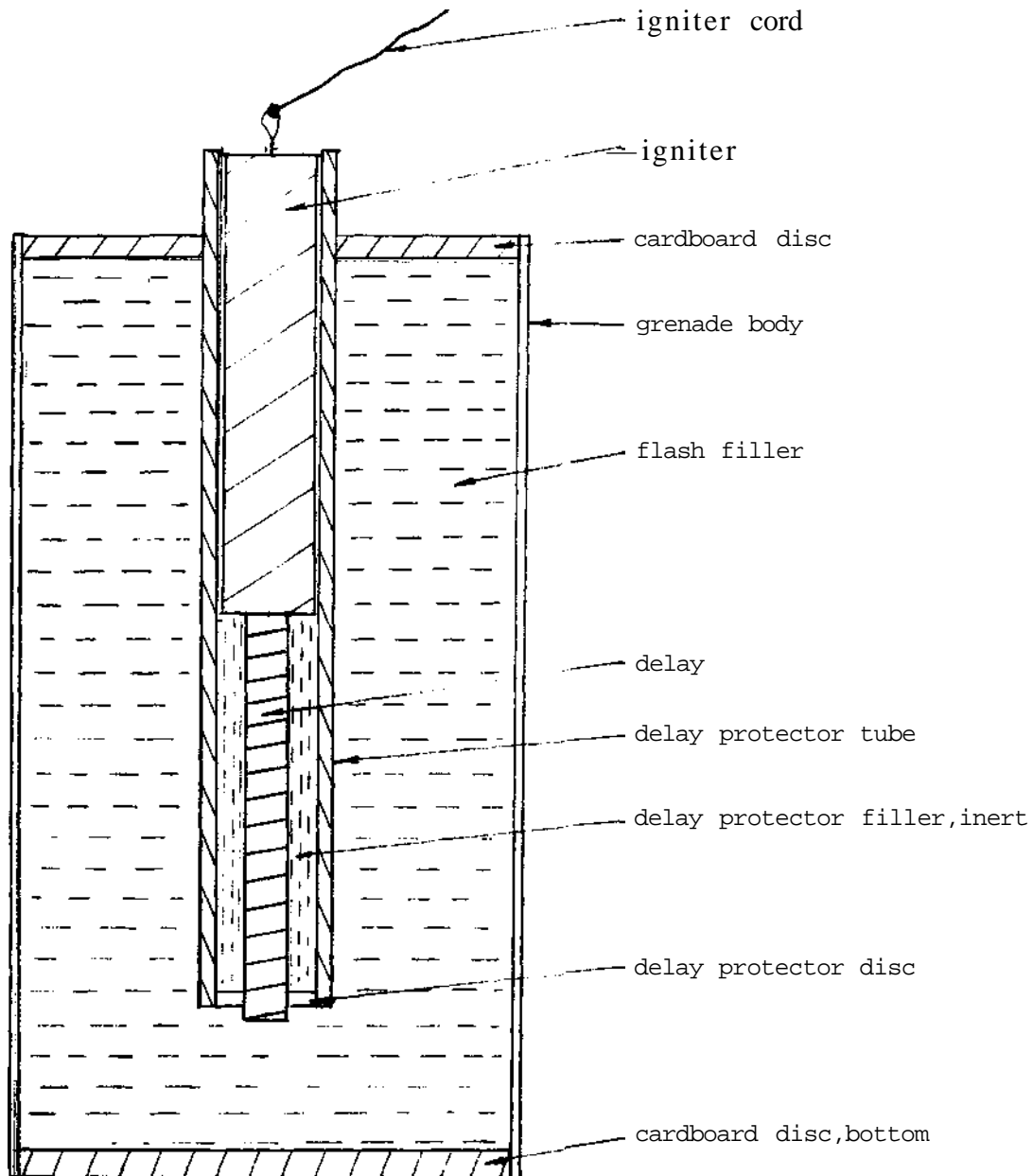

The bottom and top covers of the body tube are cut from cardboard and glued or epoxied to the tube (the top cover with a central hole, is seated only after the filler and fuse assembly are in place). Additional tape over the covers is strongly recommended.

Expedient Filler

The filler of an expedient flash grenade could be any pyrotechnic composition producing a powerful flash and explosion, and initiated by burning fuse. However, the grenade simulator mix has passed the test of time and service and may be considered as a standard.

Expedient Flash Grenade

Equipment:

- 1 - balance, 1000 gram capacity, tolerance ± 0.25 gram
- 2 - weighing bowl, stainless steel, approximate 500 ml capacity, available from supermarket, plastic cover is desirable, required 4 each
- 3 - scoop, small, stainless steel or aluminum; or large tablespoon
- 4 - blending unit, expedient design as per drawings
- 5 - sieves, U. S. standard sizes #30, 40, 60, 100, 140, 200, 230, 325: or equivalent (see "apparent density" under notes on sieves)
- 6 - workbench, approximately 4x6 feet with non-sparking and conductive top cover (aluminum or conductive rubber, glued and nailed with aluminum nails around edges); if bench frame and legs are non-conductive (wood), lead a heavy copper wire from conductive top to leg bottom to assure a solid contact with concrete (tiled or painted) floor
- 7 - graduated cylinder, glass, 250 ml capacity
- 8 - graduated cylinder, glass, 25 ml capacity

Materials:

% by weight

- | | |
|--------------------------------|----|
| 1 - Aluminum filings | 20 |
| 2 - Magnesium shavings/filings | 20 |
| 3 - Potassium perchlorate | 30 |
| 4 - Barium nitrate | 30 |

Safety Precautions:

See Chapter 6 for appropriate precautions

Procedures:

- 1 - weigh the required quantity of each component material
- 2 - screen the weighed portion through the appropriate sieve (as per material specification in chapter five)
- 3 - place each weighed and screened portion in a tightly covered container.
- 4 - transfer the containers with material to the blending area
- 5 - place the fuel (Aluminum - Magnesium) into the blender
- 6 - place the oxidizers (Potassium chlorate and Barium nitrate) on the fuels
- 7 - operate the blender remotely until the final mix is uniform in color and consistency
- 8 - by remote control transfer the blended mix onto a screen which will pass the fuel pieces
- 9 - inspect the screened mix to be free from lumps
- 10- place the screened and inspected composition into a marked and closed container

The filler is now ready for final loading

How to Build Flash/Stun Grenades

Note:

In the military practice, the storage of assembled grenades is usually avoided. Grenades are stored separately from the igniters (detonators).

Grenade simulators, however, are stored fully assembled. Since the expedient flash grenade fits both device types, either of the above storage methods would apply; common sense and safety considerations should prevail.

Expedient Flash Grenade Components

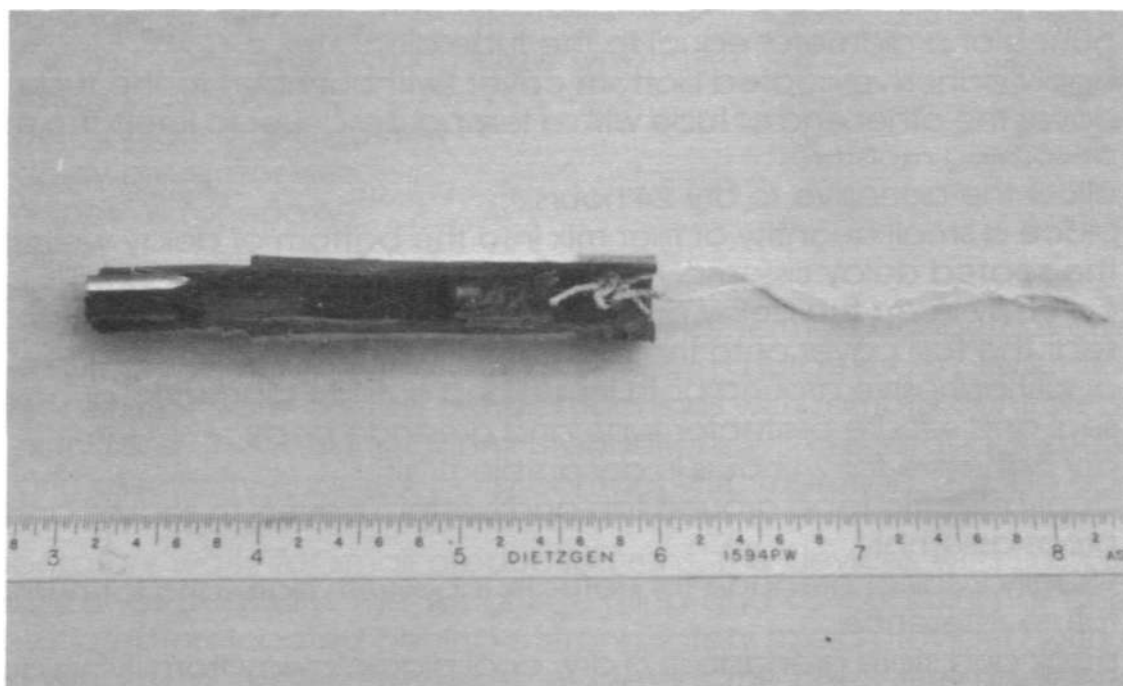

Igniter M3A1 in Cross Section

Expedient Flash Grenade

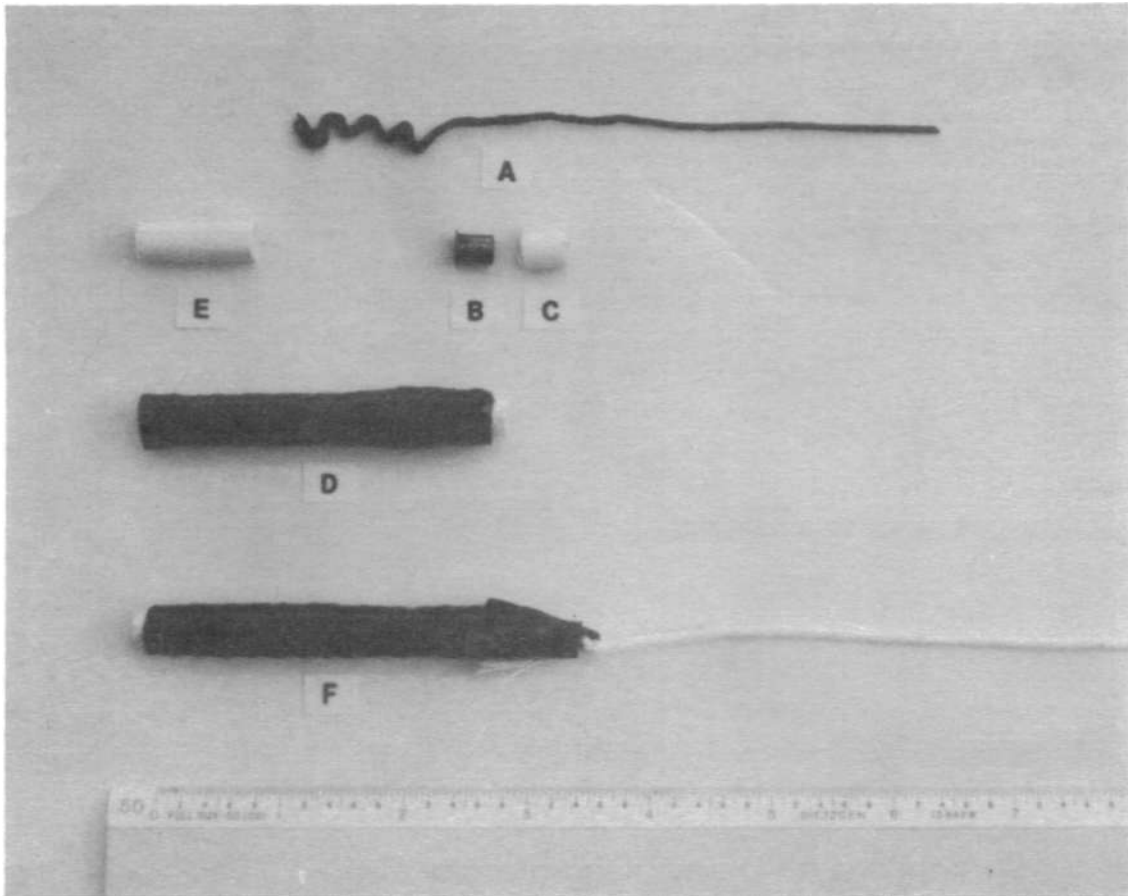

Expedient Igniter Components

- A - Igniter charge wire
- B - Cup, igniter (battery cup)
- C - Retainer for cup
- D - Tube
- E - Ferrule (tubing)
- F - Assembled expedient igniter

How to Build Flash/Stun Grenades

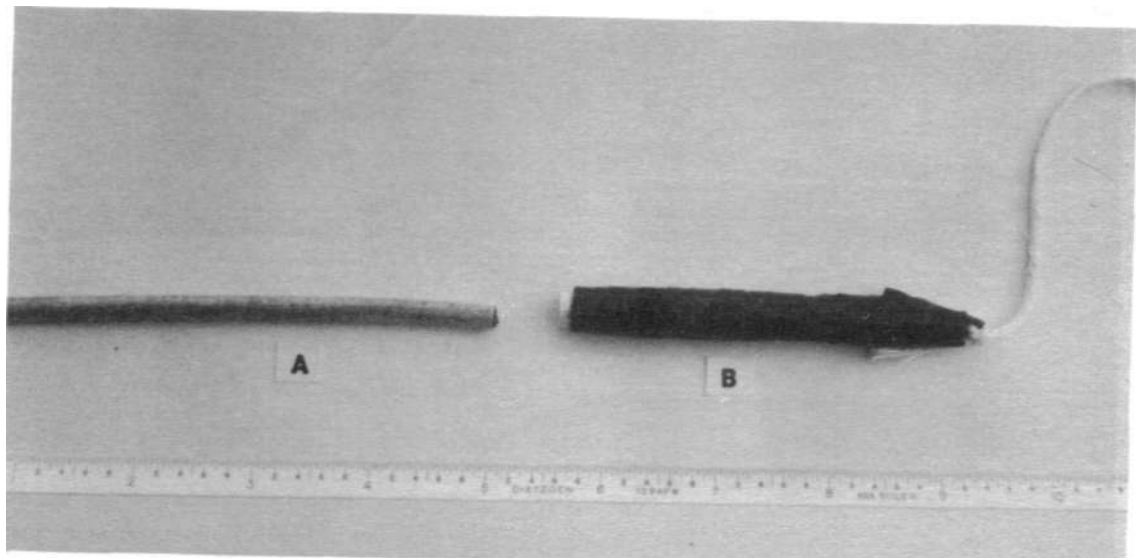

Igniter and Delay Assembly

- A - Delay (Commercial fuse)
- B - Igniter, expedient

Expedient Flash Grenade

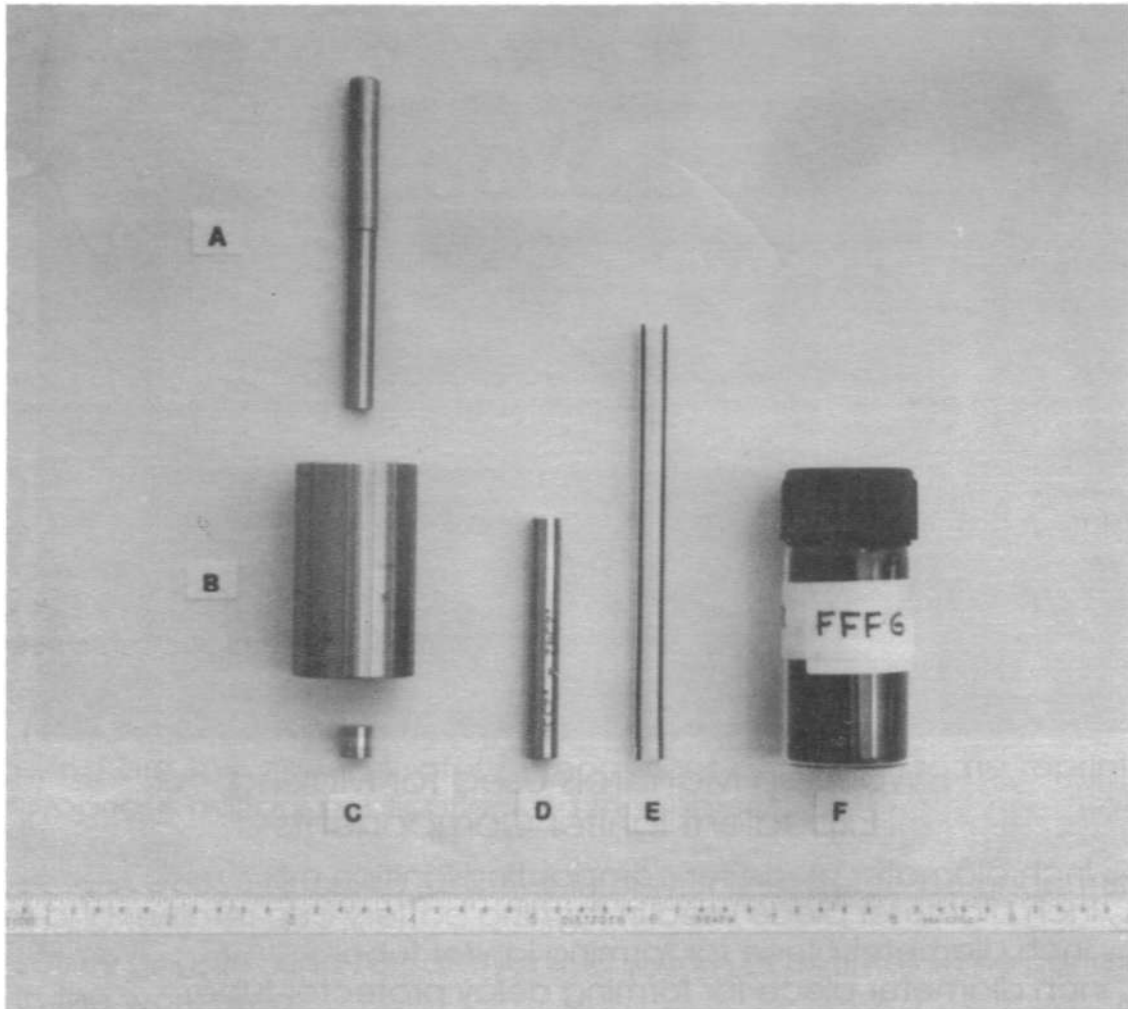

Expedient Delay Assembly Tools and Materials

- A - Ejection punch
- B- Die
- C - Bottom plug
- D - Compression punch
- E - Plastic straw
- F - Black powder

Note: The die and punches illustrated are shorter than required for a 6 seconds delay and are shown for reference only.

How to Build Flash/Stun Grenades

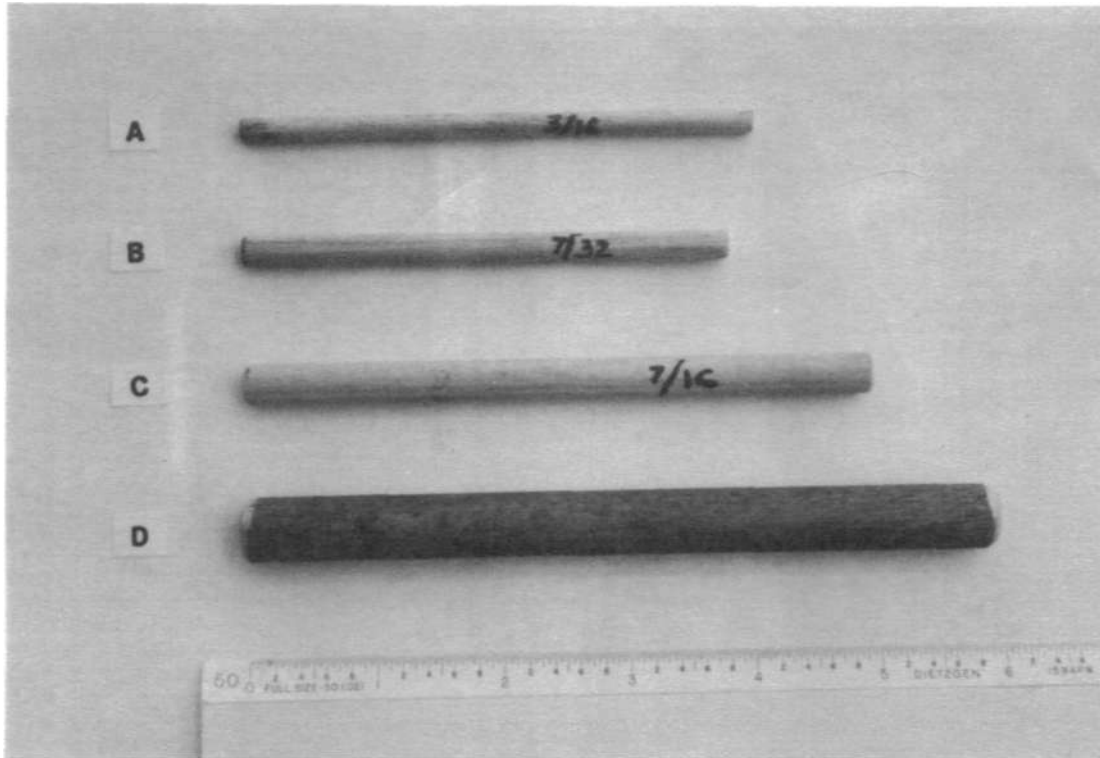

Wooden Mandrels Used for Making Expedient Igniter Components

- A - $\frac{3}{16}$ inch diameter piece for compacting ignition mix
- B - $\frac{7}{32}$ inch diameter piece used in forming battery cup retainer and ferrule
- C - $\frac{7}{16}$ inch diameter piece for forming igniter tube
- D - $\frac{5}{8}$ inch diameter piece for forming delay protector tube.

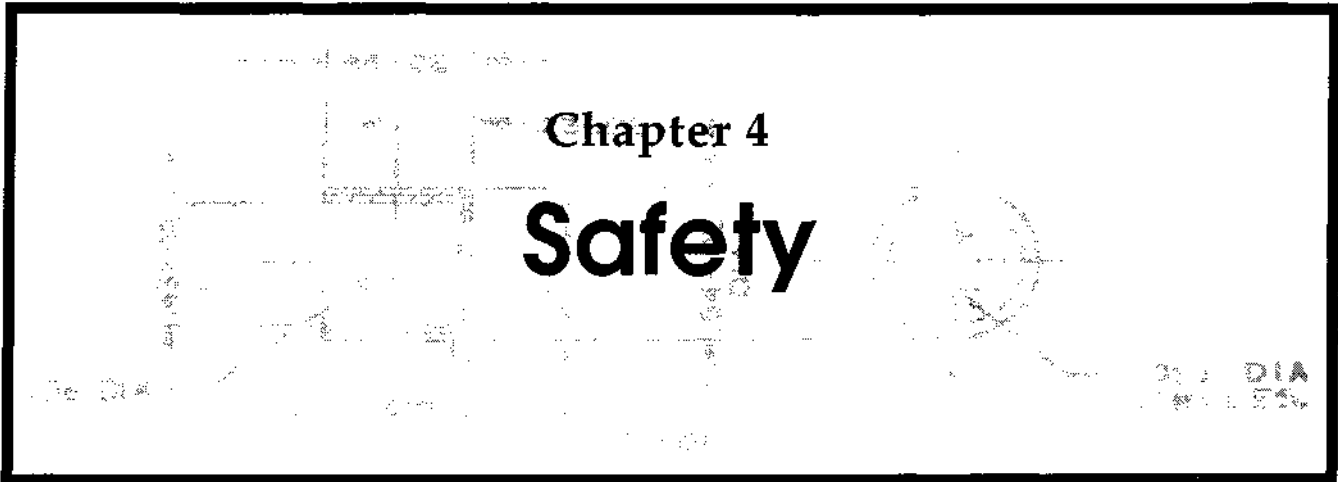

The handling of flash/illuminating composition materials is dangerous and requires the strictest attention to all details of safety. Generally the fact that the material is labeled as flash, illuminating (or tracing), and not as a high explosive, leads the unfamiliar to treat it with less respect. Nothing could be more dangerous than such an attitude.

DO NOT BE OVERCONFIDENT

Following are the general safety precautions as well as some reprints from the appropriate military publications on the subject.

- 1 - do not work undressed, or in T-shirt only; it is better to be uncomfortable than "well done" in case of a fire.
- 2 - safety goggles and / or safety shield is worn at all times while handling, or in the work area
- 3 - suitable safety shoes, preferably grounded are worn at all times while handling or in the work area
- 4 - rubber gloves to be worn when handling oxidizers
- 5 - laboratory, or safety coat to be worn during work
- 6 - do not wear silk, nylon, or synthetic material underwear, or clothing when handling the pyrotechnic components. Cotton and wool are the preferred materials to avoid static electricity build-up on your body
- 7 - remove work clothing and wash hands and face before meals. Do not eat or drink in the work area
- 8 - clean and/or change safety clothing and footwear at the end of work period
- 9 - all tools and equipment to be from non-sparking and preferably non-conductive material
- 10 - no electric equipment (electric motors, fans, heaters, etc.) are permitted in the work area where flash material and/or components are handled or stored. Expedient conditions do not justify use of shielded and explosion-proof electrical equipment.

How to build Flash/Stun Grenades

- 11 - work during daylight hours to avoid use of electric lighting. Tape over switches and outlets as safety against accidental use
- 12 - all work surfaces to be grounded
- 13 - no open fire or spark in the area where flash material and/or components are present
- 14 - observe all specific safety precautions pertinent to each material, as listed in the material specifications
- 15 - store fuels and oxidizers in separate areas
- 16 - store all materials in tightly closed conductive containers (*metallic can, etc.) on grounded surface (concrete floor) away from fire and electricity
*) Copper, brass or aluminum if compatible with the material stored
- 17 - after completion of work period (shift) clean all floors with wet mop; wipe all tools and work surfaces (benches, counter-tops, etc.) with wet cloth
- 18 - when interrupting operations, perform all steps as if work period has been completed
- 19 - stop all operations when thunderstorms are in the area (5-10 miles away) the high static in the air can cause sparking
- 20 - periodically (once a week, or more often) clean by vacuum and wipe with wet cloth, all ceilings, walls, windows, doors, etc. to remove loose dust from surfaces
- 21 - DO NOT BE OVERCONFIDENT**

Following are reprints from some specifications which describe the safety precautions at laboratories and manufacturing operations. Although some paragraphs may be repetitive, it is better to read the warning twice than omit it,

Safety

MIL-P-21355 (NOrd)

6.7 General Safety Precautions. - The loading, assembly and handling of the item covered by this specification, and the subassemblies thereof, involve hazardous operations and therefore require suitable explosives safety precautions. Use of these specifications will not be construed as to relieve the contractor or manufacturer of responsibility for the safety of his operations. Listed below are certain minimum provisions which a contractor or manufacturer (which explosively loads the item covered) should observe in order to fulfill his responsibility for safety. At Bureau of Ordnance, Navy Department, and other government plants, these provisions are mandatory. Such other warnings and precautions; pertinent to the operational effectiveness or safety during use or loading of the specified item, are included in the detail technical requirements of the specifications.

6.7.1 All loading operations should be conducted in a neat and orderly manner,

6.7.2 Safe equipment and methods should be utilized for transporting and handling explosives and loaded parts, Where required, remote control barricaded handling equipment shall be used for explosives operations, such as mixing, pouring, weighing, charging, sifting, drying, pressing, coating, crimping, etc.

6.7.3 Personnel handling detonators, primers, delay elements, lead-ins, boosters, and related parts which affect functioning, should insofar as practicable, avoid using bare fingers or improper equipment in order to prevent damage, corrosion, or deterioration from perspiration or other contaminating deposits.

6.7.4 The exposure of explosive materials and related parts shall be so controlled as to minimize the absorption of moisture from the atmosphere or other sources during loading and handling operations.

6.7.5 All explosives and completely or partially loaded items should be stored in suitable storage magazines located in accordance with the American Table of Distances (ATD) or other applicable safety standards; and, while in process, in safety lockers and chests if in loading rooms, or in adequate ready or service magazines located in accordance with intraplant distances when outside of loading rooms. For Navy managed explosives loading plants, the provisions of the Armed Services Explosions Safety Board covering quantity-distance relations for explosives will apply.

6.7.6 Proper care must be exercised at all times to protect personnel from accidents, fires or explosions, and to limit damage to equipment and loading areas. In this connection, the precautionary measures in the following paragraphs should be observed.

How to build Flash/Stun Grenades

6.7.6.1 Employ properly proportioned and properly located protective barricades, screens or shields at all required points.

6.7.6.2 Keep only minimum limited quantities of explosives and completed or partially loaded parts present at each stage of operations.

6.7.6.3 Keep explosives and explosive parts in approved covered receptacles with covers in place when material is not being taken out of or put into the receptacles. Where necessary, receptacles should be conductive to ground electrostatic charges.

6.7.6.4 Protect operations from electrostatic charges by effectively grounding all machinery, equipment, and fixtures; and, where necessary, employ suitable grounded conductive shoes. Workers' clothing of a type to minimize the accumulation of static charges should not be employed. Fabrics such as silk and nylon, which promote static generation should be employed. Additional grounding devices such as grounded bracelets for workers should be employed where operations are conducted with items which are unusually sensitive to initiation by static electricity. Such items include initiating explosives, tracer mixtures, and low-energy type electric primers, detonators and squibs. The latter types of items should have the free ends of lead wires bared and twisted together, and be packed in relatively small groups wrapped in bare non-insulated aluminum foil or other uncoated metal foil. During assembly and processing operations such sensitive electric items should be short circuited by clips or other devices until installed with safety shunt in the final device. Additional precaution for these items should include mechanical shielding to contain or deflect fragments and blast, also electrical shielding of these items from induced electric currents generated by sources such as lightning, static, radiation from communications apparatus, radar or high frequency heat apparatus, etc. Where necessary for safety, humidity of work rooms should be appropriately increased, as required to lessen electrostatic effects but without inducing excessive moisture absorption by any of the components of the item being loaded.

6.7.6.5 Protect all explosive operations from effects of electric current originating from equipment such as soldering irons, heaters, switches, wiring, motors, lights, test instruments, etc., by suitable insulation, grounding separation or shielding. Such electric sources may initiate explosives by heat, sparks, arcs, or due to completing an electric circuit through an electric primer, detonator, or squib. Circuits may be inadvertently completed, for example, from a defective electric soldering iron through a grounded contact. All electric type primers, detonators or squibs provided with wire leads should have the free ends of the wires bared and twisted together to short circuit each unit except when in process of assembly into a finished item. Where practicable, removal of short-circuiting clips, or other devices should be employed during manufacturing operations involving electric primers, detonators or squibs.

Safety

6.7.6.6 Enforce, where necessary, the wearing of suitable safety footwear, gloves, goggles, respirators, and impregnated garments to protect personnel against burns, poisoning and associated industrial hazards.

6.7.6.7 Allow no fires of exposed electrical or other sparking equipment, and little or no flammable material to be present in loading, handling and storage spaces, Enforce proper "Match" and "No Smoking" rules where necessary.

6.7.6.8 Enforce good housekeeping and maintain effective policing, inspection and supervisory methods throughout the loading area and surroundings. Employ effective cleaning methods periodically to minimize the accumulation of explosives or explosive dust and other contamination upon, and assure its removal from floors, walls, ceiling, ledges, tables, benches, piping, and equipment or the items loaded; also, clean up any spilled material immediately.

How to build Flash/Stun Grenades

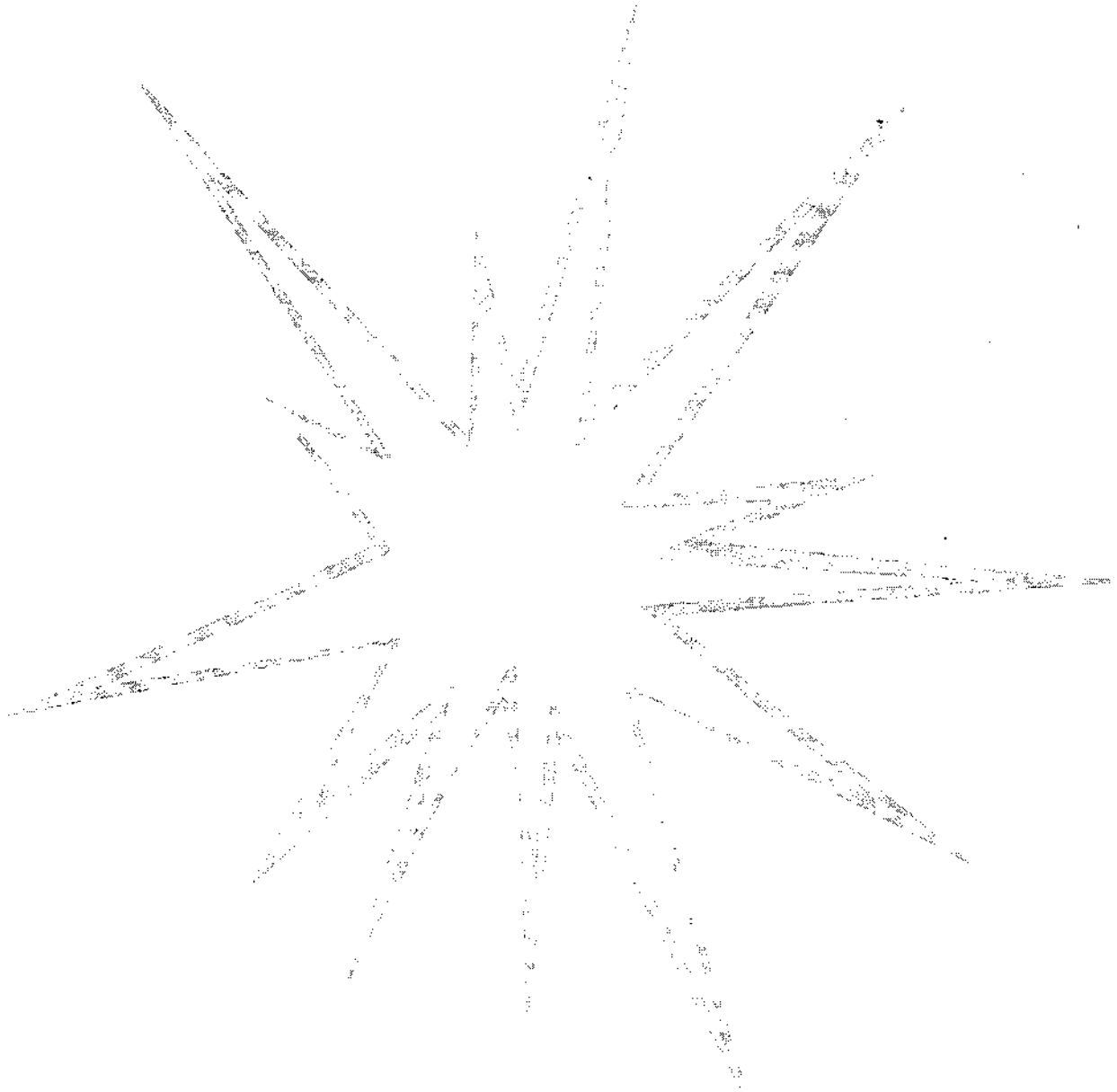

Chapter 5

Materials

The importance of the right material in the right proportion is evident to everybody who ever mixed concrete or baked a cake. The factors considered in the material selection are:

availability - the material must be readily available for preferably several commercial sources without undue restrictions

quality - the selected material should be consistently uniform from lot to lot in purity of composition and particle size

cost - obviously the material must be as inexpensive as possible

Many are the descriptions of how to make certain devices and mixes, but these descriptions seldom go into the details on specific materials. Yet professional process descriptions of military and industrial procedures devote substantial attention to the material specifications. The critical importance of this matter cannot be overemphasized.

This chapter gives specifications of each material used for the flash grenade filler and igniter. Each specification covers the quality and safety hazards of the respective material. The chemical and physical characteristics and the quality control tests are mentioned only inasmuch as they pertain to this subject. Additional sources of data are available from the military specifications and sources listed in references.

The information on materials is to be used as a guide. To obtain some or all materials conforming to the MIL specification is a privilege available to only a few. Furthermore such material sources are controlled and hence the supply is unpredictable. Therefore alternate, everyday sources are preferred.

How to Build Flash/Stun Grenades

The MIL specifications for materials are written with definite requirements to follow, such as:

- compatibility with a variety of materials
- safety in storage over many years
- utmost uniformity in performance from grenade to grenade
- adaptability to the equipment and safety procedures in existing operations
- suitability to use in many different applications, from grenade simulator through artillery shells to illuminating bombs

Obviously, while such specifications are of utmost importance, they are not sacred. This not to contradict all previous statements, but to underline that the requirements for an expedient grenade are simpler to satisfy without sacrifice of SAFETY, PERFORMANCE, & RELIABILITY

MATERIAL	SPECIFICATIONS (SEE NOTE)	REMARKS
Illuminant composition	MIL-STD-718	
Powder, photoflash	MIL-P-466	
Powder, photoflash	MIL-P-48239	
Acetone	O- A- 51*	
Aluminum, atomized	JAN-A 289 or MIL-A-512	
Barium nitrate	MIL-B-162	
Binder, cell, nitrate-camphor	MIL-B-10854	
Binder	MIL-STD-708	
Charcoal	JAN-C-178	
Dextrin	MIL-D-3994	
Drier	TT-D-643	
Ethanol	MIL-E-463 or O-E-760*	
Magnesium	JAN-M-382	
Magnesium-Aluminum alloy, powdered	JAN-M-454	
Phosphorus, red	MIL-P-670	
Potassium chlorate	MIL-P-150	
Potassium perchlorate	MIL-P-217	
Shellac, orange	TT-S-271*	
Sodium nitrate	MIL-S-322	

Note: * Refers to Federal Standards

Materials

Acetone, Technical

Federal specification: O-A-51, technical grade

Chemical formula: $\text{CO}(\text{CH}_3)_2$

Formula weight: 58.08

Technical description: liquid, colorless, volatile, pungent sweetish odor, highly flammable

Properties

Density	0.79
Boiling point	56.2° C
Freezing point	-93.0° C

Solubility: Miscible with water, alcohol, and many organic solvents in all proportions

Storage: In tightly closed container with filling opening in upward position. In cool, well ventilated place, away from heat and open flame; properly stored the shelf life is indefinite

Use: Industrial solvent for extraction, various laboratory applications

Personnel hazards: Inhalation of vapor is irritating to respiratory tracts; skin contact may cause irritation

Fire and explosion hazards: extremely volatile flammable liquid; vapor forms explosive mixture with air at temperatures above 4° F. Extinguish with water.

How to Build Flash/Stun Grenades

Aluminum, Powder

Military specification: MIL-A-512

Chemical formula: Al

Formula weight: 26.98

Technical description: white-grayish metallic powder, free from grits, impurities and lumps

Properties: Apparent density 1.10 ± 0.10

Granulation, (passing through U. S. Std. sieve)

#40 99.5% min.

#230 30.0% min.

#325 50.0% max.

Requirements, chemical

Al, min, %.....	98.75
Cu, max, %.....	0.5
Fe, max, %.....	0.5
Si, max, %.....	0.5
Mg, max, %.....	0.1
Zn, max%.....	0.25
Other elements, Total, max., %.....	0.5
Total of all impurities, max., %.....	1.25
Alkalinity as Mg(OH) ₂ max., %.....	0.07
Nonvolatile matter, min., %.....	99.95
Easily extracted fatty and oil matter, max., %.....	0.2

Storage: closed container, in dry area, separated from oxidizers; properly stored the shelf life is indefinite

Use: fuel in pyrotechnic mixes

Personnel hazards: none

Fire and explosion hazards: mixed with oxidizing materials produces an incendiary and explosive composition

WARNING: never use Aluminum powder with Sodium nitrate mixture because of the chemical instability of such mixture in presence of moisture.

Materials

Barium Nitrate

Military specification: MIL-B-162, class 2

Chemical formula: Ba(NO₃)₂

Formula weight: 261.35

Technical description: white crystalline powder, odorless, free from lumps

Properties: melting point 590° f

Solubility:

(in water at 20°C) 8.7g/100ml

(in water at 100°C) 34.2 g/100ml

insoluble in alcohol

Granulation (passing through U.S. Std. sieve)

#30 99.5% min.

#200 2.0 % max.

Requirements, Chemical:	percent by weight
Barium nitrate, min.	99.0
Iron and aluminum (as oxides), max.	0.50
Calcium and Magnesium (as oxides) max.	0.50
Sodium (as Na ₂ O), max.	0.15
Chloride (asBaCl ₂), max.	0.0075
Grit, max.	0.05
Moisture, max	0.10
pH	5.0-8.0
Insoluble matter, max.	0.10

Storage: in moisture-proof container, in cool dry place away from open flame and fire hazard; properly stored its shelf life is indefinite

Use: oxidizer, in priming compositions, photoflash compositions, propellents, flares

Personnel hazards: poisonous if swallowed, avoid contact with eyes, ears, nose, throat and skin, avoid breathing dust; when burning evolves toxic fumes

Fire and explosion hazards: may cause fire on contact with readily oxidizable materials; by itself the fire hazard is moderate, as a strong oxidizing agent it reacts vigorously when heated with a fuel and may even detonate. Quench fire with large volume of water.

Note: technical grade powders are usually 90-100 mash granulation

How to Build Flash/Stun Grenades

Binder for igniter components

Military specification: MIL-B-10854

Chemical composition:

Material	Percent by weight
Cellulose nitrite(*)	80.0 ± 2.5
Camphor(**)	20.0 ± 2.5

(*) Cellulose nitrate to be newly prepared and with following chemical Composition:

Nitrogen content of cellulose nitrate (by wt.)	11.1%
Ash (by weight)	0.2%
Residual solvent	0.8%
Material insoluble in acetone at 24° ± 3°C	0.2%

(**) material to be suitable for plasticizing cellulose nitrate

Storage: keep binder in tightly closed container, away from heat and fire

Personal hazards: none

Fire and explosion hazards: both, components and finished binder are flammable materials to be kept away from open fire

Binder for Photoflash Composition

Military specification: MIL-STD-708, class 2

Chemical composition:

Material	Percent by weight
resin, Laminac 4110, American Cyanide Co.	98.0 ±0.1
catalyst solution(*)	1.5 ± 0.1
drier, TT-D-643	0.5 ±0.1

* 60% solution of methyl-ethyl ketone peroxide in dimethylphtalate

Blending instructions:

- Mix binder in required quantity immediately prior to use
- mix resin and catalyst thoroughly prior to addition, add drier

Storage: follow instructions of manufacturers of component materials

Personnel hazards: follow instructions of manufacturers of components

Materials

Charcoal

Military specification: JAN-C-178, class C

Technical Description: material to be prepared by destructive distillation of willow, alder, or suitable hardwood in such a manner as to produce charcoal of the best composition and cleanliness of burning; free from unburned wood and grit

Properties:

moisture content	5.0% max. (by weight)
ash content	5.0% max. (by weight)
granulation (passing through U. S. Std. sieve #100)	99.9% min.

Storage: in closed moisture-proof container, away from heat and flame: properly stored its shelf life is indefinite

Use: fuel in pyrotechnic compositions, odor absorbent in liquor and food industry

Personnel hazards: avoid breathing dust

Fire hazard: flammable solid, keep away from oxidizers and flame

Note:

-brown tint of material indicates incomplete carbonization

- shaking sample in a bottle of water and repeated pouring-off reveals presence of grit and impurities

How to Build Flash/Stun Grenades

Dextrin

Military specification: MIL-D-3994

Chemical formula: $(C_6H_{10}O_5)_n \times H_2O$

Technical description: white, amorphous powder, free from impurities and lumps

Properties: solubility in 3 parts of boiling water

Requirements, chemical	percent by weight, max.
Particle size; material retained on a No. 80 (117 micron) sieve	0.5
Uncombined water	5.0
Ash	0.15
Water-insoluble matter	2.5
Acidity (as acetic acid)	0.18
Reducing sugars (as dextrose)	4.0

Storage: in tightly closed container in cool dry place

Use: industrial adhesive

Personnel hazards: none

Fire hazards: will burn if ignited; quench with water.

Materials

Ethanol (Ethyl Alcohol)

Military specification: MIL-E-463

Federal specification: O-E-760, type III

Chemical formula: C₂H₅OH

Formula weight: 46.07

Technical description: clear, colorless liquid, very volatile, with wine-like odor, burning taste

Properties: boiling point 78.6°C

density 0.789 g/ml

solubility: miscible with water and many organic solvents in all proportions

Storage: in tightly closed container with filling opening up; away from heat and flame in a well ventilated place; when sealed in air-tight container lasts indefinitely

Use: general industrial and laboratory solvent, used in organic synthesis, cleaning solutions, antifreeze

Personnel hazards: although not considered an industrial poison, large doses cause nausea, vomiting, lack of coordination, even death; inhalation produces same symptoms as ingestion

Fire and explosion hazard: readily ignited by flame spark, or static electricity discharge. Forms explosive mixture with air. Fire may be extinguished with water

How to Build Flash/Stun Grenades

Magnesium Powder

Military specification: JAN-M-382

Chemical Formula: Mg

Formula weight: 24.32

Technical description: silvery-white powder consisting of granular or spheroidal particles, tarnishes to gray color upon exposure to air

Properties: Apparent density depends on the granulation

granulation:

U. S. Std. sieve #	percent by weight
16 100	100 pass through min.
30 120	97 pass through min.

Requirements, chemical:

percent by weight

Free metallic Magnesium (min.)	98
Volatile at 105°C (max.)	0.10
Oil and grease (max.)	0.02
Carbides (max.)	0.004
Material insoluble in sulfuric acid (max.)	0.15
Metallic iron (max.)	0.05
Total iron as Fe ₂ O ₃ (max.)	0.25

Storage: in tightly closed container away from water, oxidizers and flame, Building to be well ventilated at highest point to eliminate accumulation of hydrogen gas resulting from reaction of magnesium powder and moisture. Properly closed stores indefinitely.

Use: pyrotechnic compositions, industrial thermite

Personnel hazards: moderately toxic, particles which perforate skin may produce local tumors; inhalation of dust or fumes irritates respiratory tracts

Fire and explosion hazards: contact with water may cause ignition and explosion of hydrogen generated by chemical reaction of Mg-H₂O. Dust or flakes can be ignited by spark or match. Highly explosive, especially in presence of oxidizers. In case of fire use sand, earth or carbon dioxide type fire extinguisher; DO NOT USE WATER, it only helps the fire.

Note: handling magnesium powder, use only non-sparking tools and containers; good housekeeping by repeated removal of dust and powder from floors, walls, and furniture is essential.

Materials

Magnesium Powder

This material is one of the most important fuels in the flash composition with high energy output in the form of light and heat. The atomized type of magnesium is produced by a high speed jet of molten metal (surrounded by a stream of inert gas) into a cooling chamber (also full of inert gas). The liquid metal breaks up into tiny droplets which solidify and are collected. Another method pours the molten metal on a disc rotating at high speed (also in an inert gas atmosphere). The size and form of the final particles is obtained by controlling the conditions of the process used.

The pyrotechnic characteristics of the magnesium powder in a composition depend on the ease with which it ignites and burns. Thus granulation plays the most important part since it determines the total surface area available to oxidation (burning). Basically coarse powder (large particles) burns more slowly while fine powder burns very fast.

Magnesium - Aluminum alloy, Powdered

Military specification: JAN-M-454 type A (50/50) type B (65/35)

Technical description: silvery-white metallic powder tarnishes to gray color upon exposure to air

Properties: apparent density depends on the type and granulation (for type A = 0.80)

granulation: passing through U. S. Std. sieve	percent min. by weight
#100	99.5
#230	45

Storage: same as magnesium powders

Use: pyrotechnic compositions, industrial thermite, aluminum paints

Personnel hazards: same as magnesium

Fire and explosion hazards: the same, but slightly reduced, as for magnesium

Note: During WWII when the atomization of metals was not fully developed and the demand for this material was high, the Mg-Al alloy was the main source of this type of fuel. The alloy is brittle and hence could be cut and granulated better than the individual metals alone. The performance of the alloy lies between the two metals. Commercial grades of Mg-Al alloys are available in compositions from 75/25 to 30/70 and in granulation mesh #60 through mesh #325, depending on the application.

How to Build Flash/Stun Grenades

Phosphorus, Red

Military specification: MIL-P-670

Chemical formula: P

Formula weight: 30.97

Technical description: reddish-brown powder

Properties:	density	2.2
	ignition point:	approx. 260°C
	insoluble in hot water	
	granulation:	U. S. Std. sieve #325 90% pass through, min.

Requirements, chemical:	% by weight
phosphorus, red	98.9 min,
phosphorus, white	0.02 max.
acidity	0.10 max.
moisture	0.20 max.

Storage: in tightly closed container in a dark cool place, away from oxidizers

Uses: fuel in pyrotechnic compositions, safety matches, light metal castings, flame resistant coatings and finishes, polyurethane hard foams

Personnel hazards: poisonous on inhalation or ingestion, slower acting than yellow phosphorus (50 mg of yellow P ingested is fatal.) Phosphorus is especially dangerous to eyes and should never be allowed to come in contact.

Fire and explosion hazards: dangerous fire hazard, easily ignited by spark or friction. Dangerous when in contact with organic materials and fuels. It can ignite SPONTANEOUSLY in air, emits toxic fumes when heated. Use wet sand

Materials

Potassium Chlorate

Military specification: MIL-P-150, grade B

Chemical formula: KClO_3

Formula weight: 122.55

Technical description: white, odorless, crystalline powder; free from lumps

Properties: apparent density of loose powder: 0.81

melting point: 368° C

decomposition at $\pm 400^\circ\text{C}$ giving off oxygen

solubility:

solvent	g/100 ml of solvent
water at 20°C	7
water at 100°C	57
methanol at 25°C	0.1
ethanol at 25°C	0.8
ethylene glycol at 25°C	1.2
acetone	insoluble

Requirements, chemical

Percent by weight

KClO_3	99.5 min.
water insoluble	0.10 max.
Potassium chloride	0.10
moisture	0.05 max.

Storage: in tightly closed metal container, in a cool dry place, away from fire and separated from flammable materials. Under these conditions the shelf life is indefinite

Use: strong oxidizing agent for pyrotechnic compositions, explosives, matches, dyes, paper, bleaches, disinfectant, printing of textiles, source of oxygen

Personnel hazards: moderately toxic, irritating to gastrointestinal tract and urinary tract, and kidneys; ingestion causes hemolysis of red blood cells and methemoglobinemia. Avoid inhalation of dust. Material spilled on skin to be washed with soap and water immediately. For eyes flush with water and get medical attention.

Fire and explosion hazards: material is sensitive to friction, explodes by shocks and heat, forms explosive mixture on contact with organic or oxidizable materials. Reaction with strong mineral acids (nitric, sulphuric) evolves explosive chlorine dioxide.

Potassium Chlorate (continued)

Clothing contaminated with chlorate or its solution is dangerously flammable; remove clothing immediately and wash with water (hot) thoroughly. Spillage on floor to be swept and removed immediately. Quench fire with large quantity of water.

Note: the danger of spontaneous ignition of chlorate-sulfur compositions is reduced when potassium bicarbonate is added to the formula.

Materials

Potassium Perchlorate

Military specification: MIL - P- 217, grade A (low moisture), class 5

Chemical formula: $KClO_4$

Formula weight: 138.55

Technical description: white, odorless, crystalline powder, free from lumps

) **Properties:** apparent density: 1.26

melting point (decomposes 400°C into KCl + 4O₂)

/ Solubility: .

solvent	g/100 ml of solvent
water at 0°C	0.7
water at 100°C	21.8
acetone at 25°C	0.15
methanol at 25°C	0.1
ethanol at 25°C	0.01

granulation: U. S. Std. sieve
#140

% by weight pass through
100

Requirements, chemical:

% by weight

potassium perchlorate	99.0 min
potassium chlorate	0.10 max.
potassium chloride	0.10 max.
moisture	0.02 max.
water insolubles	0.02 max.

Storage: in tightly closed container away from water, organic materials and flammable materials. Under these conditions the shelf life is indefinite.

Use: strong oxidizer in pyrotechnic and explosive compositions, solid rocket propellants, photography, medicine.

Personal hazards: moderately toxic, inhalation to be avoided, irritates mucous membranes and respiratory tract; ingestion causes muscle contraction, irritation of gastrointestinal tract, may affect kidneys. Heated perchlorate emits highly toxic fumes. If material comes in contact with skin, wash affected area with soap and water immediately. For eyes, wash with water and get medical attention.

Fire and explosion hazards: mixed with organic materials, powdered metals or sulfur forms explosive compound. Clothing or combustible material contaminated with perchlorate or its solution is dangerously flammable. Remove clothing immediately and wash thoroughly with hot water. Spillage on floors to be swept and removed immediately.

How to Build Flash/Stun Grenades

Potassium Perchlorate (continued)

Note: although perchlorate contains more oxygen than chlorate, it is less liable to decompose (being a salt of perchloric acid which is more stable than chloric acid). It may be used in some instances as a substitute for potassium chlorate and can be used safely with sulfur. Since it is more difficult to ignite than chlorate, it may require a starting fire.

Materials

Powders, Metal

Military specification: MIL-P-14067

This specification is a partial consolidation of specifications

MIL-A-289

MIL-A-512

MIL-M-382

MIL-M-454

The specification MIL-P-14067 is included in this text as a sample only. Such specification, while essential for military applications is not necessarily followed in industrial use, and is definitely not absolutely required for expedient devices.

In the industrial practice the specifications of materials are dictated by the requirements of the one particular product being manufactured. The availability "off-the-shelf" (from several sources) and the cost are also of importance. Military specifications of a given material must cover multiple applications of a given material, hence they have the classes, types, granulations, etc. etc. The inspection procedures and other data are given to eliminate their inclusion in the respective purchase orders, contracts, etc. Generally, the suppliers of materials follow, or even exceed the requirements of the specification.

How to Build Flash/Stun Grenades

Powder, Photoflash

Military specification: MIL-P-48239

Chemical composition:

Material	Specification	Percent by weight	
		type 1 class A	type III class A
Magnesium	MIL-M-382	34.0 ± 1.0	
Aluminum	MIL-P-14067	26.0 ± 1.0	40.0 ±2.0
Potassium perchlorate	MIL-P-217	40.0 ± 1.0	30.0 ±2.0
Barium nitrate	MIL-B-162		30.0 ±2.0

Note: moisture contents of composition not to exceed 0.1%

Technical description: finished powder to be a uniform mixture free from lumps or the tendency to form lumps

Storage: do not store in mixed proportion (load and pack into the appropriate device immediately after blending). Blend in quantity required for immediate use only.

Use: filler in photo flash ammunition

Personnel hazards: Same as pertaining to each individual component of mix. Fire and explosion hazards: sensitive pyrotechnic mix, readily ignited by flame or spark.

Materials

Powder, Photoflash

Military specification: MIL-P-466 A, type III, class A

Chemical composition:

Material	Specification	Percent by weight	Granulation
Aluminum	JAN-A-289	40.0 ± 1.0	20 ± 5
Barium nitrate	JAN-B-162	30.0 ± 1.0	75 ± 25
Potassium perchlorate	JAN-P-217	30.0 ± 1.0	17 ± 2

Note: moisture contents of composition not to exceed 0.1 %

Technical description:

finished powder to be a uniform mixture free from lumps or the tendency to form lumps

Storage: do not store in mixed proportion (load and pack into the appropriate device immediately after blending). Blend in quantity required for immediate use only.

Use: filler in photo flash ammunition

Personnel hazards: same as pertaining to each individual component of mix.

Fire and explosion hazards: sensitive pyrotechnic mix, readily ignited by flame or spark.

How to Build Flash/Stun Grenades

Sodium Nitrate

Military specification: MIL-S-322

Chemical formula: NaNO_3

Formula weight: 85.0

Technical description: colorless, transparent, odorless, crystalline powder; saline, slightly bitter taste

Properties:

melting point	306°C
solubility:	
solvent	g/100 ml of solvent
Water at 0°C	73
Water at 100°C	180
Acetone	Slightly
Ethanol	slightly
granulation: U.S. Std. sieve #	percent by weight
60	98 min.

Requirements, chemical:

	Percent by weight
Sodium nitrate	99.5 min.
Sodium chloride (NaCl)	0.15 max.
Sulfate	0.2 max.
Water insolubles	0.1 max.
Moisture	0.5 max.

Storage: tightly closed in a cool, dry place away from fire and organic materials and fuels. Material is very hygroscopic. Properly stored, its shelf life is indefinite.

Use: oxidizer in pyrotechnic and incendiary compositions, glass, matches, pottery enamels, pickling meats, fertilizers.

Personnel hazards: moderately toxic, avoid contact with skin and ingestion; emits toxic fumes when heated above 1000°C with reducing materials.

Fire and explosion hazards: dangerous fire and explosive material, can ignite on friction with organic and other readily oxidizable materials. Fire is controlled by flooding with water.

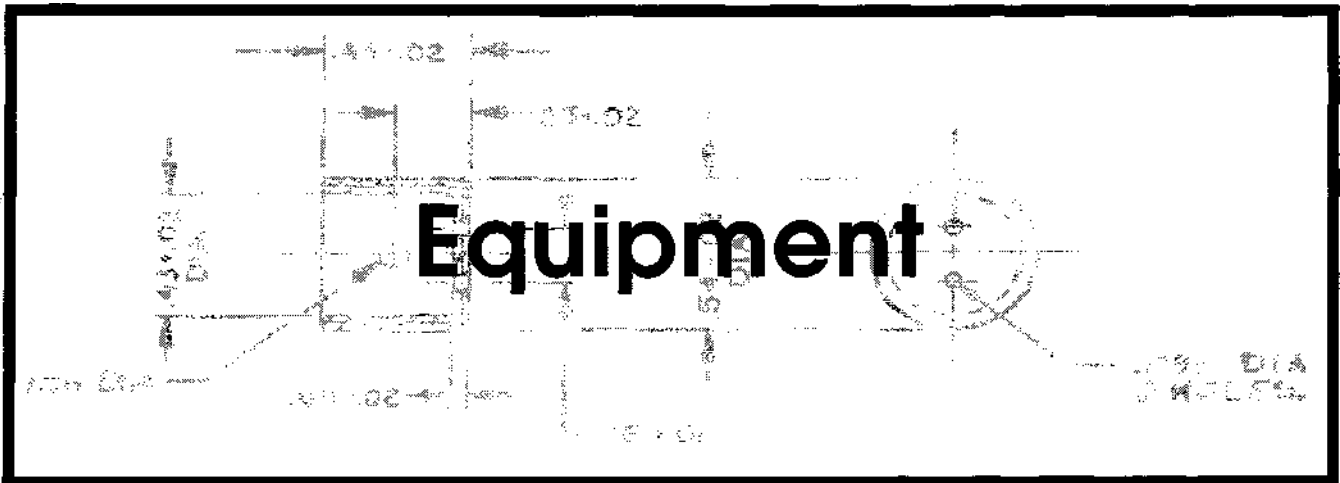

Since the particle size of the flash mix components is of critical importance, the way to measure them is also important. The particle size is measured by screening them through sieves of different sizes. The sieves used in the industry are described by the Federal Specification RR-S-366; a diameter with a woven wire cloth, or perforated plate bottom. The table below shows the U. S. Sieve series sizes which are of concern to this study.

Sieve designation		Sieve opening	
Standard	Alternate	Mm	In Approx. Equivalents
2.00 mm	No. 10	2.00	.0787
1.68 mm	No. 12	1.68	.0661
1.19mm	No. 16	1.19	.0469
595mm	No. 30	.595	.0234
420 mm	No. 40	.420	.0165
297mm	No. 50	.297	.0117
250mm	No. 60	.250	.0098
177 mm	No. 80	.177	.0070
149mm	No. 100	.149	.0059
125mm	No. 120	.125	.0049
105m	No. 140	.105	.0041
74mm	No. 200	.074	.0029
63mm	No. 230	.063	.0025
44mm	No. 325	.044	.0017
37mm	No. 400	.37	.0015

It is desirable to have a uniform sample (100 gram) for testing the sample material.

How to Build Flash/Stun Grenades

- a- from each lot of material take a uniform sample (100 gram)
- b- arrange the sieve column (if using standard sieves) in order of decreasing openings towards the bottom of the column; with the receiving pan on bottom
- c -place weighted sample on top sieve and shake manually 10 minutes
- d -disassemble the column and weigh the amount of sample on each sieve
- e -in humid weather heat the sieve and sample in an oven at 50°C for 10-15 minutes to prevent sieve binding

It is not always possible to obtain a set of standard sieves (also they are quite expensive). The substitute sieves made from mosquito screen, kitchen sieves, thin muslin cloth, etc. may not cover adequately the range of sizes required. Therefore an alternate method may be used, based on the apparent density of the material.

Density, by definition, is the ratio weight to volume. In the standard practice the density of water is taken as 1, i.e. material which weighs 1 gram and occupies 1 ml of volume has density of 1. However, in practice powder and loose materials are not put into a die in a hydraulic press to compress them into a minimum volume, prior to measuring their density. Powders are measured in loose form and the value is called "apparent density." There are several methods used in determining the apparent density, three of which are given below. Whichever method is chosen, it should be stuck to, switching from one method to another will only lead to confusion.

Apparent density as per JAN-M-545:

Place a tared (weighted empty and labeled accordingly) container with inner volume of 1 cubic inch under a funnel, Pour slowly sample powder into the hopper until the container is filled to overflowing. Strike off excess powder from the container top surface carefully with a spatula without jarring the container. Weigh the container and its contents and calculate the apparent density(corrected to grams/ml).

Apparent density as per MIL-P-14067, 4.3.14

Plastic funnel with a stem of 1/4 inch internal diameter is cut so that the end of the stem is just over the uppermost graduation of a tared 100 ml graduated cylinder. Fill the cylinder to 100 ml mark by pouring small quantity of sample on the funnel side and allowing it to trickle by gravity through the stem. Avoid jarring or tapping the cylinder. Weigh the cylinder and its contents. Increase in weight over tared, divided by 100 is the apparent density.

Apparent Density (British Method)

Take a heavy wall test tube, approximately 6 inches high by 0.8 inches in diameter. Pour in 20ml water and mark the level (on the outside of tube) and

Equipment

label 0.5. Pour the water out. Pour in 10ml water and mark the level 1.0. Repeat the operation with 5.0 ml (label 2.0), 8.0 ml (label 1.25). Now we have an apparent density measuring device.

Place 10 gram sample powder into the calibrated test tube and close with a rubber stopper. Drop the closed test tube 30 times from a height of 2-1/2 inches onto a piece of hard rubber. Measure the level of sample and read off the apparent density.

Each of the above methods has its merits and disadvantages. The first method which is the most accurate requires an apparatus called Scott Volumeter. Although this method is used almost exclusively in ballistic laboratories for determination of propellant powder density, it is definitely not an expedient model and method.

How to Build Flash/Stun Grenades

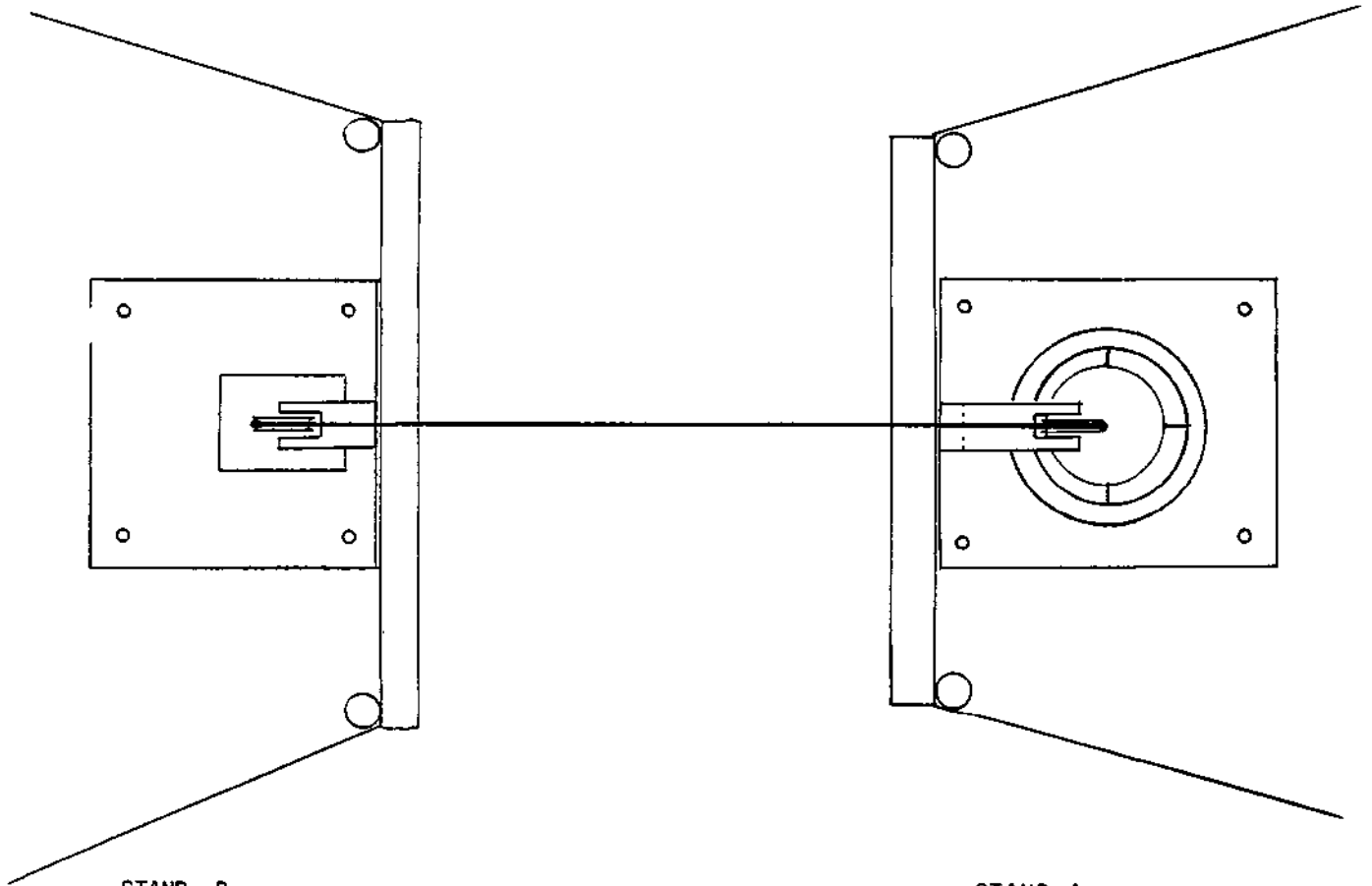

STAND B
operator location

STAND A
pyrotechnic composition
location

EXPEDIENT PYROTECHNIC COMPOSITION BLENDING SYSTEM
top view

Equipment

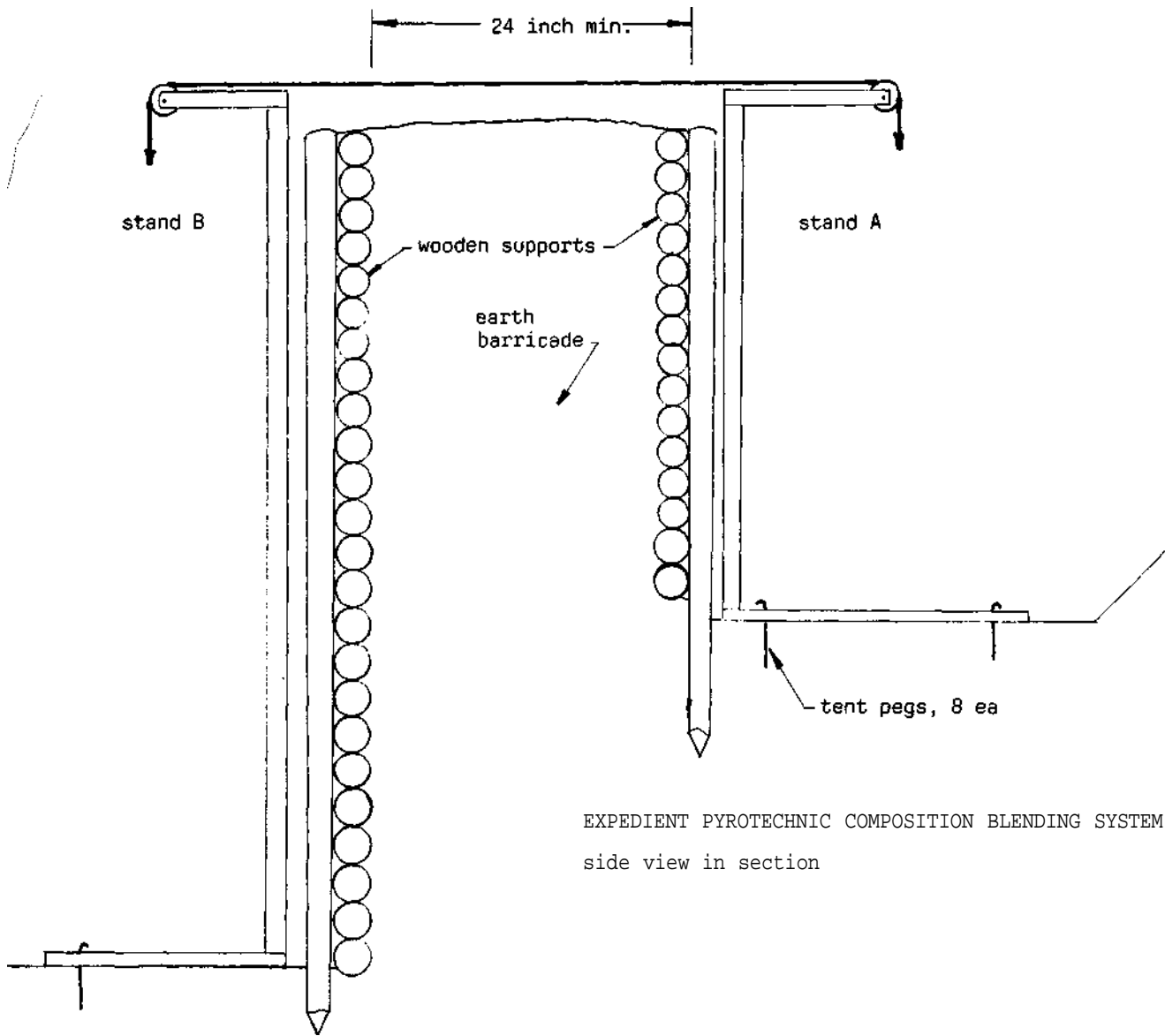

EXPEDIENT PYROTECHNIC COMPOSITION BLENDING SYSTEM
side view in section

How to Build Flash/Stun Grenades

PORTABLE PYROTECHNIC COMPOSITION BLENDER - STAND A

Note: all wood construction, glued and screwed together. Support rings cut from 1" plywood and glued to support arms
 Silk bag support ring made from 3/16 Al wire pulled through 4 eyebolts (eyebolts glued into holes in funnel ring).

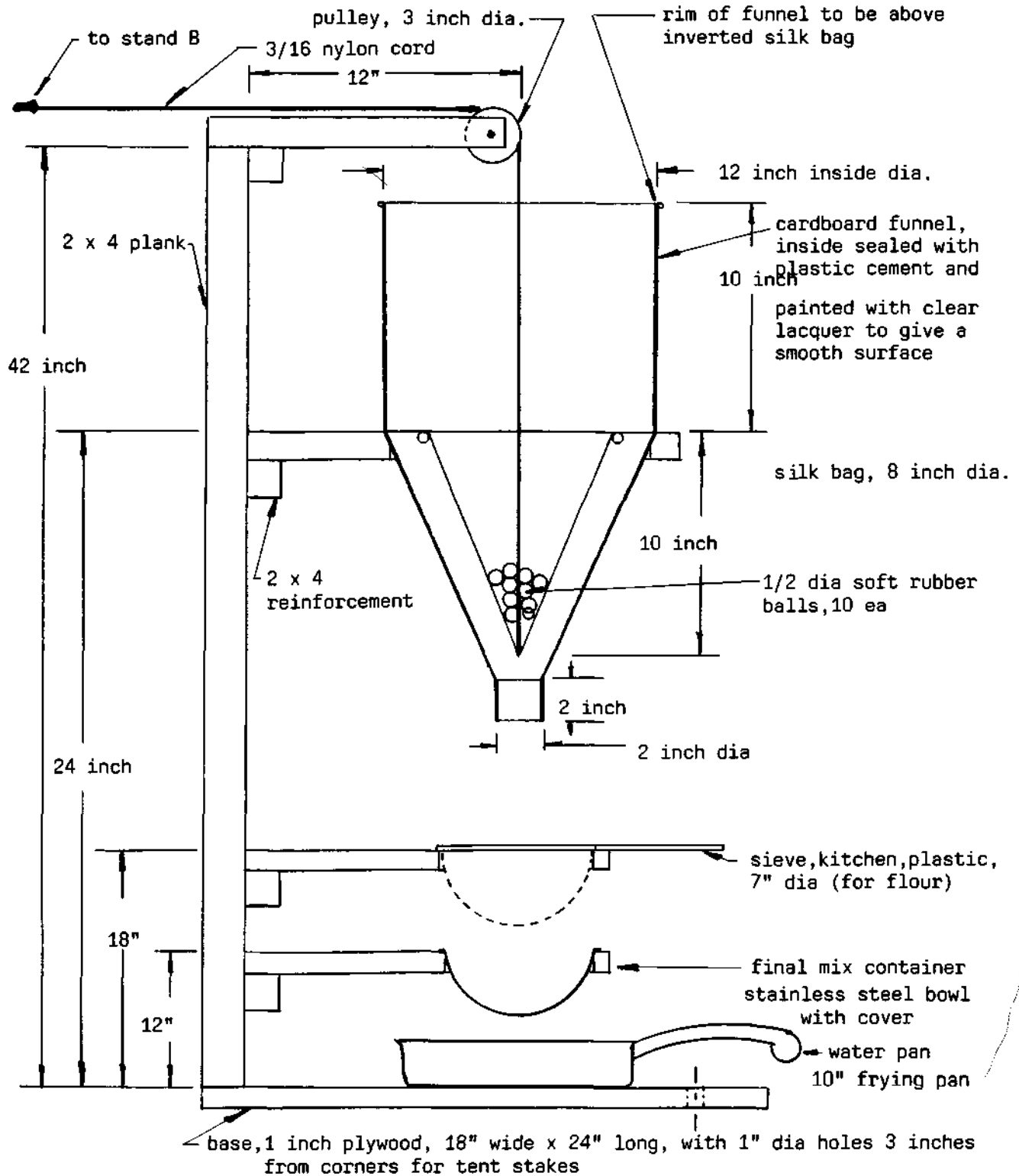

Equipment

Notes on blender construction:

- 1 - Frame components should be screwed and glued tight and solid (except the adjustable plates in stand B)
- 2 - The cardboard funnel should have about 2 inches clearance around the blending bag and be about 1 inch above the top of inverted bag position
- 3 - The screen (sieve) and bowl supports holes should be cut to fit the items on hand; dimensions given are for the items in the author's kitchen
- 4 - Painting or spraying of the finished frames with clear shellac makes them easier to clean
- 5 - The hold-down stakes are plastic or aluminum tent pegs available from military surplus or camping goods stores
- 6 - Dug-in ground construction requires some manual work, but the finished system is safer and cheaper than over-ground barricades and concrete walls
- 7 - Canvas roof over the blender stand A gives protection from dust and sun

How to Build Flash/Stun Grenades

PORTABLE PYROTECHNIC COMPOSITION BLENDER - STAND B

Note: dimensions are indicative only, may be adjusted on location

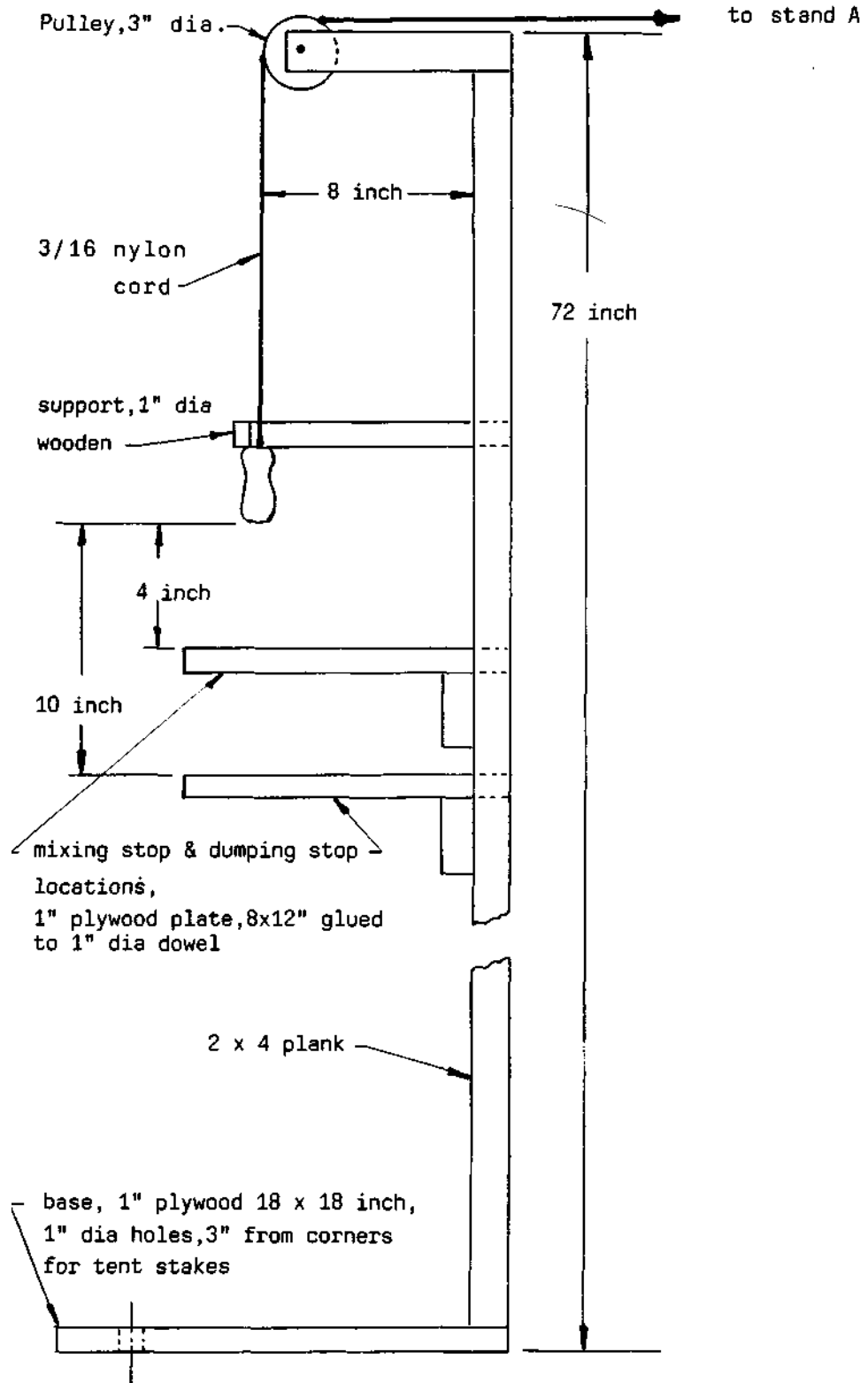

Equipment

PORTABLE PYROTECHNIC COMPOSITION BLENDER - STAND AB

Note: all wood construction, glued and screwed together.

Blending sheet of densely woven light material is in the shape of 30 inch triangle with all sides equal

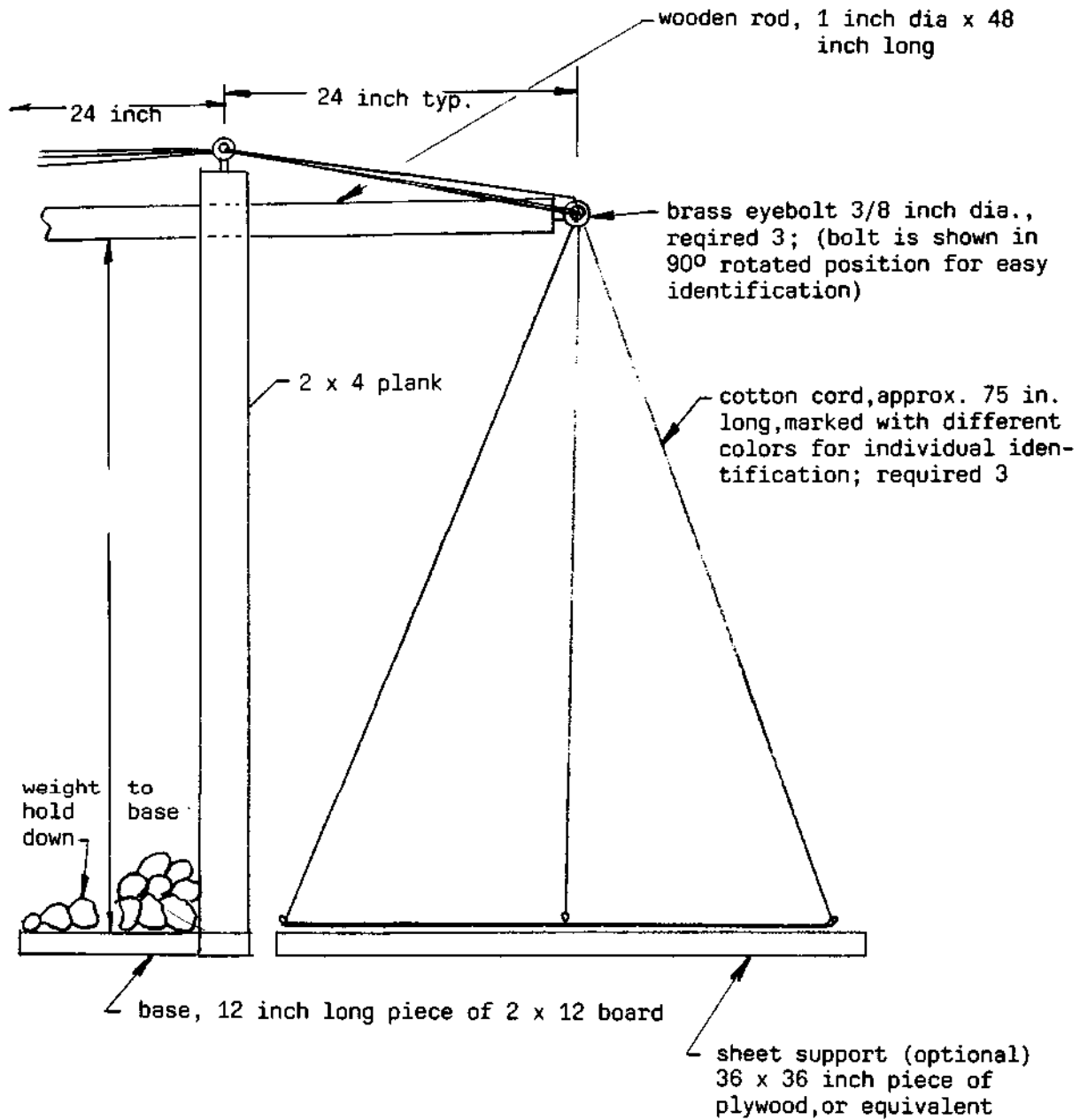

How to Build Flash/Stun Grenades

EXPEDIENT FLASH GRENADE FILLER COMPACTING DIE ASSEMBLY

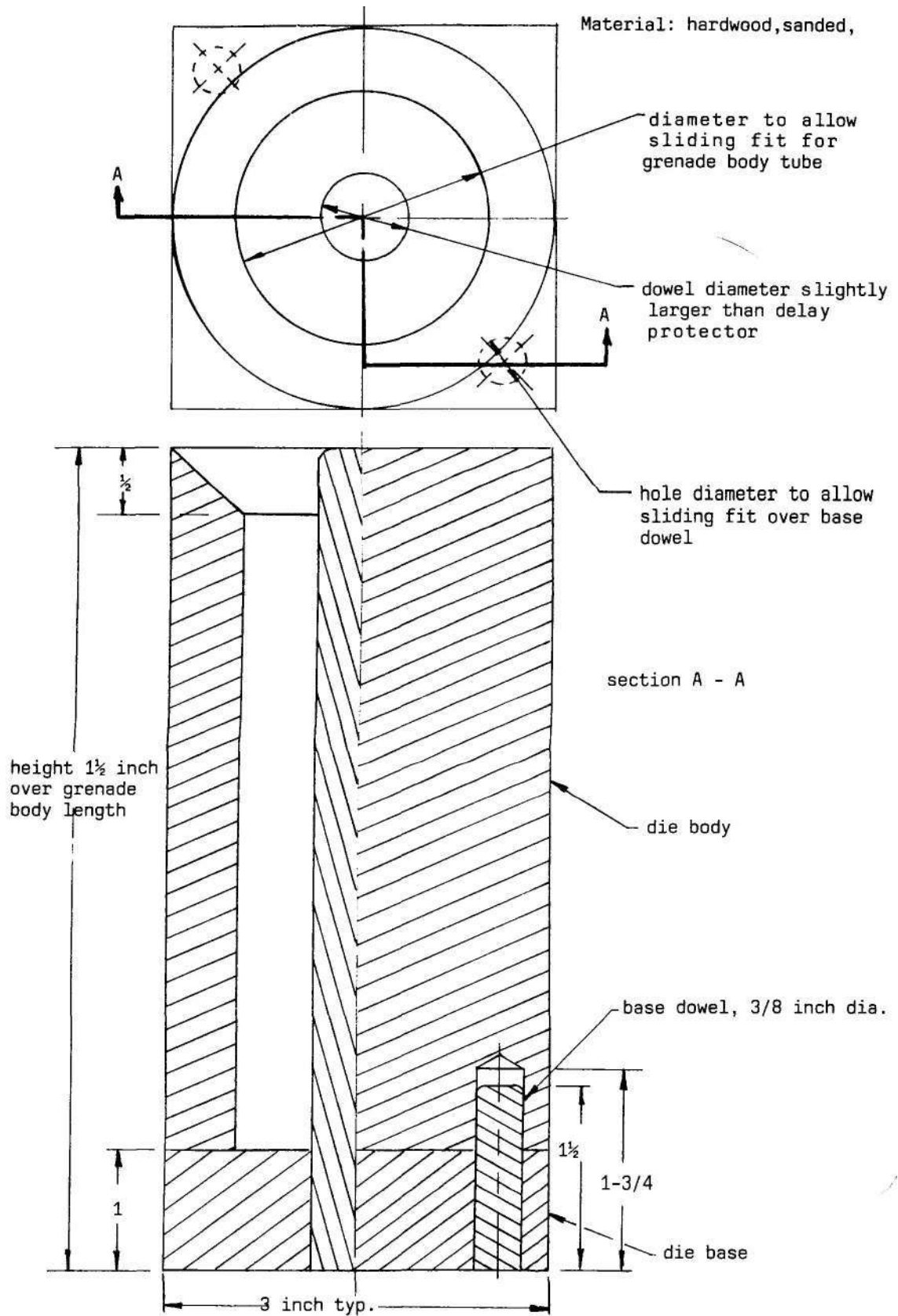

Equipment

EXPEDIENT FLASH GRENADE FILLER COMPACTING PUNCH

Material: hardwood, sanded

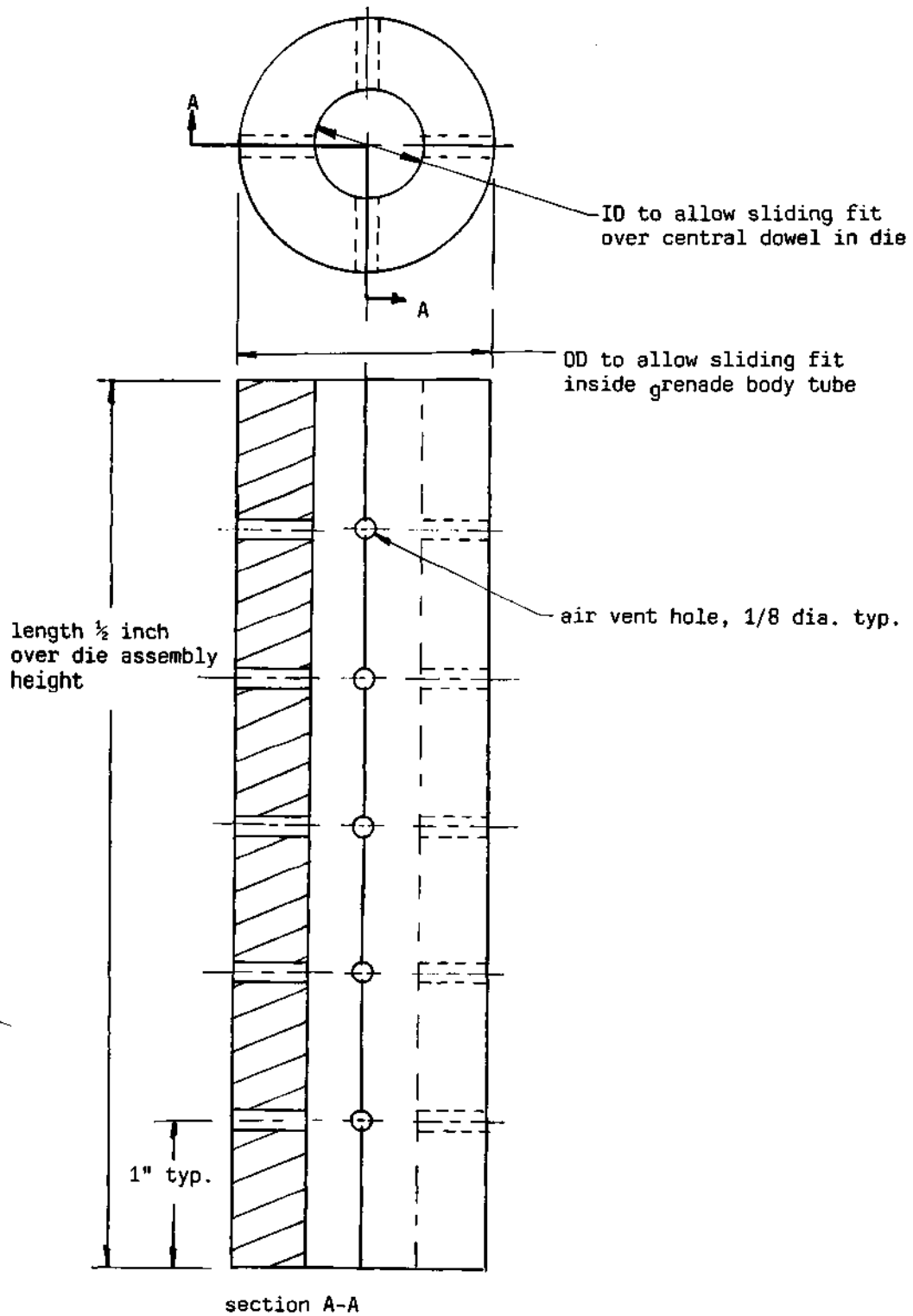

How to Build Flash/Stun Grenades

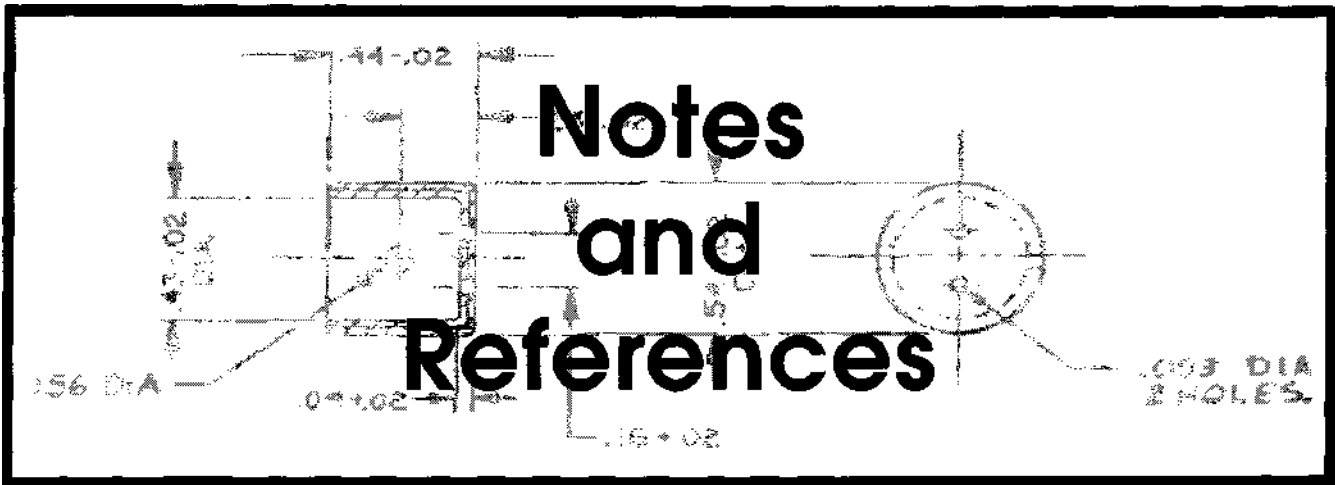

References:

DOD4145.26M DOD Contractor's Safety Manual for Ammunition, Explosives and Related Dangerous Materials, Oct. 1968

NTIS #AD272424 NOLTR 61 -138 Explosives, Propellents and Pyrotechnics Safety, covering laboratory, pilot plant and production operations, 20 Oct. 1961

TB CML 50 Chemicals and Chemical Products, Department of the Army, Oct. 1961, military specifications and standards and Federal Specifications listed in the text

Glossary

- | | |
|-----------------|---|
| Boiling Point - | temperature at which the vapor pressure of a liquid is equal to the external pressure (usually assumed as one atmosphere) |
| Corrosive - | a caustic or acid material causing destruction of living tissue or destructive effect on metal. |
| Dehydration - | removal of water from a substance by drying, heating, centrifugation, chemical reaction, etc. |
| Delay - | explosive train component introducing a controlled time delay in some phase of functioning of a fuse |
| Density - | mass per unit of volume of a material at a specific temperature; in chemistry is expressed as grams/milliliter |

How to Build Flash/Stun Grenades

desiccant -	material used to absorb water vapor within a container
expedient -	a military term applied to a system or device which is not a standard issue. It may be constructed in the field from standard issue components, or from locally available materials. Construction and/or use of expedient devices is performed by personnel with experience and expertise above that of average enlisted men.
flash grenade -	a grenade whose principal effect is to produce a blinding flash of light; incendiary and/or blast effects, if present are of secondary use only.
formula weight -	the sum of atomic weights of all atoms present in a chemical formula. Example: H_2O , formula weight = $1 \times 2 + 16 = 18$.
freezing point -	temperature at which the liquid and solid exist together in equilibrium and the transition is from liquid to solid.
fuse -	1.) tubular or cord-like container filled with deflagrating (safety fuse) or detonating (detonating fuse) material used to transfer a flame or blast from an ignition mechanism to the main charge. Only safety fuse is used as a delay element. 2.) a device designed to initiate the action of an ammunition item
grenade -	an explosive missile designed to be thrown by hand, launched from a device attached to the muzzle of a rifle barrel or fired from a light, hand carried grenade launcher.
hazardous substance -	material which is toxic, corrosive, strong oxidizer, flammable, explosive, and capable of causing serious injury or illness to personnel during handling or use
hygroscopic -	ability to absorb moisture from the atmosphere, but not enough to dissolve the material
illuminating grenade -	a grenade whose principal effect is to provide light over an area for a relatively long period of time. It is used mainly to prevent the opponent from taking advantage of darkness.

Notes and References

melting point -	temperature at which liquid and solid exist in equilibrium and the transition is from solid to liquid
miscible -	a property of liquids to be mixed with one another in any proportion
simulator, grenade -	a pyrotechnic device designed to imitate the sound, flash and blast of a hand grenade; it is used in troop training. The grenade simulator is handled with the same precautions as prescribed for its service counterpart
solubility -	the weight of a substance which will dissolve in a given volume of solvent at a specific temperature, producing a saturated solution. It is generally expressed as weight in grams dissolved in 100 ml of a given solvent
squib -	small and simple initiator consisting of a body (usually cylindrical) containing an explosive charge and bridge wires. When energized, the squib generates gas and/or flame without blast effect, hence it is used mainly to initiate pyrotechnic devices.
volatility -	rapid evaporation of a material due to its high vapor pressure

How to Build Flash/Stun Grenades

MIL-P-14067B(MU)
10 March 1967
SUPERSEDING
MIL-P-14067A(MU)
13 February 1963

MILITARY SPECIFICATION POWDERS, METAL (FOR USE IN AMMUNITION)

1. SCOPE

1.1 This specification covers three types of atomized metal powders and one type of ellipsoidal metal powder. (see 6.3 or 6.5).

1.2 Classification. - The metal powders shall be of the following types:

- Type I -Magnesium Powder, Atomized.
- Type II -Aluminum Powder, Atomized.
- Type III -Magnesium-Aluminum Alloy Powder 65/35, Atomized.
- Type IV -Magnesium Powder, Ellipsoidal.

2. APPLICABLE DOCUMENTS

2.1 The following documents of the issue in effect on date of invitation for bids form a part of this specification to the extent specified herein.

SPECIFICATIONS

FEDERAL

UU-P-236 - Paper, Filter, Analytical

STANDARDS

FEDERAL

MIL-STD-105 -Sampling Procedures and Tables for Inspection
by attributes (ABC-STD-105)

MIL-STD-109 -Inspection Terms and Definitions.

MIL-STD-129 -Marking for Shipment and Storage.

MIL-STD-1233 -Procedures for Determining Particle Size,

-Particle Size Distribution and Packed Density of Powdered Materials

FSC:6810

Notes and References

MIL-P-14067B(MU)
10 March 1967

MIL-STD-1234 -Pyrotechnics, Sampling, Inspection and Testing

PUBLICATIONS

"American Society for Testing and Materials."

ASTM Designation E 34-58 - Chemical Analysis of Aluminum
and Aluminum Base Alloys.

(Application for copies should be addressed to the American Society for Testing Materials, 1916 Race Street, Philadelphia, Pennsylvania, 19103).

(Copies of specifications, standards, drawings and publications required by contractors in connection with specific procurement functions should be obtained from the procuring activity or as directed by the contracting officer.)

2.2 Other publications. - The following document forms a part of this specification to the extent specified herein. Unless otherwise indicated, the issue in effect on date of invitation for bids shall apply.

Code of Federal Regulations

49CFR 71-90 - Interstate Commerce Commission Rules and Regulations for the Transportation of Explosives and other Dangerous Articles.

(The Interstate Commerce Commission Regulations are now a part of the Code of Federal Regulations (1949 Edition and revisions) available from the Superintendent of Documents, Government Printing Officer, Washington 25, D. C. Orders for the above publication should cite "49 CFR 71-90 (latest revision).")

3. REQUIREMENTS

3.1 Shape

3.1.1 Type I, III, and IV. The shape of metal powders type I, III, and IV particles shall be spheroidal when tested as specified in 4.3.1 (see 6.3)

3.1.2 Type II. - The shape of metal powders atomized type II particles shall be spheroidal or granular when tested as specified in 4.3.1 (see 6.3).

3.1.3 Type IV -The shape of the ellipsoidal magnesium shall be spheroidal with a maximum of 30 percent oblong shape particles when determined as specified in 4.3.17. (see 6.6)

How to Build Flash/Stun Grenades

MIL-P-14067B(MU)
10 MARCH 1967

3.2 Chemical and physical properties. -The metal powders shall conform to the chemical and physical requirements as in Table I.

3.3 Granulation. -The metal powder shall conform to the granulation requirements as in Table II when tested as specified in 4.3.15.

3.4 Average particle diameter. The average particle diameter shall conform to the requirements in Table III when tested as specified in 4.4.13

4. QUALITY ASSURANCE PROVISIONS

4.1 General quality assurance provisions. -The supplier is responsible for the performance of all requirements specified herein. Except as otherwise specified, the supplier may utilize his own or any other inspection facilities and services acceptable to the Government. Inspection records of the examinations and tests shall be kept complete and available to the Government as specified in the contract or order. The Government reserves the right to perform any of the inspections set forth in the specification where such inspections are deemed necessary to assure that supplies and services conform to prescribed requirements. Reference shall be made to Standard MIL-STD-109 in order to define the terms used herein. Inspection shall be performed in accordance with this specification and other specifications referenced in any of the contractual documents.

4.1.1 Contractor quality assurance system. If the contractor desires to utilize a quality assurance system which is at variance with the quality assurance provisions of 4.2 and 4.3 and other documents referenced herein, he shall submit a written description of the system to the contracting officer for approval prior to initiation of production. It shall include a description covering controls for lot formation and identification, inspection to be performed, inspection stations, sampling procedures, methods of inspection and provisions for control and disposition of non conforming material. The written description will be considered acceptable when, as a minimum, it provides the quality assurance required by the provisions of 4.2 and 4.3 and the other documents referenced herein. The contractor shall not be restricted to the inspection station or the method of inspection listed in this specification provided that an equivalent control is included in the approved quality assurance procedure. In cases of dispute as to whether certain procedures of the contractor's system provide equal assurance, the comparable procedures of this specification shall apply. The contractor shall notify the Government of, and obtain approval for any change to the written procedure that affects the degree of assurance required by this specification or other documents referenced herein.

MIL-P-14067B(MU)
10 March 1967

TABLE I

Requirements

TYPES

	I Magnesium Powder	Aluminum Powder	65/35 Magnesium Aluminum Alloy Powder	IV Ellipsoidal Magnesium	
Magnesium, percent minimum (min.)	98.0		65 plus or minus 5	98.0	4.3.5
Aluminum, percent min.		98.75	35 plus or minus 5		4.3.10
Volatile material at 105 degrees Cent. (°C) percent maximum	0.1	0.1	0.1	0.1	4.3.2
Oil and Grease percent (max.)		0.2	0.2		4.3.8
Zinc, percent, max.	1.5	0.3		0.5	4.3.6
Silicon percent, max.		0.25	0.2		4.3.9
Alloy as Iron, percent, max.	0.5	0.55	0.1	0.05	4.3.4
Carbides percent, max	0.004			0.004	4.3.3
Other impurities, percent, max	0.3			1.0	4.3.8

MIL-P-14067B(MU)
10 March 1967

TABLE I

Requirements

TYPES

	I Magnesium Powder	II Aluminum Powder	III 65/35 Magnesium Aluminum Alloy Powder	IV Ellipsoidal Magnesium	V Spheroidal Magnesium
Total aluminum and Magnesium percent min.			98.0		4.3.12
Apparent density gram (gm) per milliliter (ml) min.	0.95	1.0	1.0	0.95	4.3.14
Nitrogen, PPM, max	20.0			20.0	4.3.18

For Type III Magnesium/Aluminum used method 4.3.12.

1
1

MIL-P14067B(MU)
 10 March 1967

TABLE II GRANULATION
 Percent Passing by Weight

Nominal mesh size U. S. Standard Sieve No.	20/50	30/50 Type 1 Magnesium	50/100	100/200
16	100 min			
20	95 min	95 min	>..>	
30	70 min	85 min	95 min	100 min
40				
50	20 max	40 max	70 min.	90 min
60	10 max	25 max		
80				
100		5 max	40 max	50 min
140			20 max	
200			5 max	30 max
325				5 max

Type II Aluminum
 Percent Passing by Weight

200.....	
325.....	

Type III 65/35 Magnesium Aluminum
 Percent Passing by Weight

30.....	100 min
50.....	90 min
100.....	50 min
200.....	30 max
325.....	5 max

TABLE II (Continued)

Percent Retained On

Type IV Magnesium

U. S. Standard Sieve No.

20.....	0.1 max
30.....	7.0 max
40.....	43-53
50.....	40-56
60.....	0-30

TABLE III. Average Particle Size, in Microns

Nominal mesh size Powder type	20/50	30/50	50/100	100/200	200/325
I	450 plus or minus 50	350 plus or minus 50	200 plus or minus 25	125 plus or minus 25	22 plus or minus 8
II	-	-	-	-	22 plus or minus 8
III	-	-	-	125 plus or minus 25	22 plus or minus 8
IV	-	350 plus or minus 50	-	-	-

Notes and References

MIL-P-14067B(MU)
10 March 1967

4.1.2 Submission of product. -At the time the completed lot of product is submitted to the Government for acceptance the contractor shall supply the following information accompanied by a certificate which attests that the information provided is correct and applicable to the product being submitted:

a. A statement that the lot complies with all quality assurance provisions of the approved current written description of the system.

b. Quantity of product inspected.

c. Results obtained for all inspection performed.

d. Specification number and date together with an identification and date of changes.

e. Certificates of analysis on all material procured directly by the contractor when such material is controlled by Government specifications listed in any of the contractual documents.

f. Quantity of items in the lot.

g. Date submitted.

The certificate shall be signed by a responsible agent of the certifying organization and shall be accompanied by evidence of the agent's authority to bind his principal.

4.1.3 Government Verification. -Using the contractor's written quality assurance procedure, when applicable, this detail specification and other contractual documents as a guide, the government inspector shall verify all quality assurance operations performed by the contractor. Verification shall be in accordance with a or b, below, as applicable, the decision being the responsibility of the procuring activity. In either case, the inspector shall also ascertain, prior acceptance, that all quality assurance provisions of other specifications referenced in any of the contractual documents have been complied with. Deviations from prescribed or agreed upon procedures discovered by the government inspector shall be brought to the attention of the contractor. Disposition of the product and remedial action shall be as directed by the government inspector and, depending upon the nature of the deviation, may consist of lot rejection, screening, resampling, re-instruction of the suppliers employees or other appropriate action.

How to Build Flash/Stun Grenades

MIL-P-14067B(MU)
10 March 1967

Unless otherwise approved by the contracting officer, the inspection lot size of metal powders deliverable under the contract shall not be less than the smallest weekly estimate of quantities contractually scheduled for production during the contract period nor more than the largest quantity contractually scheduled for delivery during the month of the contract period. Inspection lots shall be homogeneous and of a size convenient to the contractor. The classification of defects shall be in accordance with Standard MIL-STD-105.

4.2.2 Examination. -Sampling plans and procedures for the following classifications of defects shall be in accordance with Standard MIL-STD-105 except that inspection for critical defects, when listed, shall be 100 percent. At the option of the procuring activity, AQL's and sampling plans may be applied to the individual characteristics listed using an AQL of 0.40 percent for each major defect and an AQL of 0.65 percent for each minor defect.

4.2.2.1 Drum sealed (see 5.1)

Categories	Defects	Method of Inspection	Code No.
Major:	AQL 0.40 percent		
101.	Weight of contents.....	Scale	01001
102.	Gasket missing or cover improperly closed.....	Visual	01002
Minor:	AQL 0.65		
201.	Marking misleading or unidentifiable	Visual	01003

4.2.3 Testing

4.2.3.1 Sampling lot. -A random sample of 8 containers shall be selected from each lot. When lots are comprised of 10 containers or less each container shall be sampled.

4.2.3.1.1 Preparation of composite for chemical tests. -Approximately one ounce primary samples of material shall be removed from each of the ten containers in order to equal eight ounces, and if there are less than 8 containers, equal primary samples in sufficient quantity to equal 8 ounces, shall be removed from each container. The individual primary samples shall then be combined in order to form a homogeneous composite sample of eight ounces and subjected to the tests specified in 4.3. If the composite sample fails to comply with any of the requirements specified, the lot shall be rejected.

Notes and References

MIL-P-14067B(MU)
10 March 1967

4.2.3.1.2 Sampling for granulation and particle size. - Each container shall be rolled and tumbled for ten minutes or until the metal powder is completely mixed in the container. Then a sample of approximately 8 ounces shall be removed from the container with a sampling thief. The granulation and particle size shall be determined on the sample thus obtained. Each container shall be individually tested. If any sample fails to comply with the requirements of Table II and III the container shall be rejected.

4.3 Test methods and procedures. -The following test methods shall be classified as major defects.

4.3.1 Shape. -Code number 02001. -A small portion of the sample shall be placed under a microscope and examined for conformance to paragraph 3.1.

4.3.2 Volatile material at 105°C. Code number 03001. -Approximately 5 gm. of the sample shall be weighed into a tared dish and heated in an oven for 3 hours at 105°C, then cooled and weighed. The loss in weight shall be calculated as percent volatile material at 105.°

4.3.3 Carbides. -Code number 04001

4.3.3.1 -Apparatus. -Apparatus similar to that shown on figure 1 shall be used.

4.3.3.2 Reagent. -A 0.25 gm. portion of gelatin shall be dissolved in hot water. The solution shall be diluted to 500 ml. and 500 ml. of 95 percent ethyl alcohol and 1.25 gm. hydroxylamine hydrochloride shall be added.

4.3.3.3 Procedure. A weighed portion of 50 gm. of magnesium powder shall be added to the reaction flask (A). Approximately 50 gm. of cuprous chloride shall be transferred to test tube (B). Nitrogen shall be passed through the apparatus to remove the air and shall be continued throughout the determination. The test tube shall be lowered and 15 ml. of concentrated ammonium hydroxide (NH₄OH) and 30 ml. of hydroxylamine hydrochloride reagent added to the reaction flask. The test tube shall be raised, the stopper inserted, 100 ml. of distilled water from dropping funnel (C) added the heater switched on. The mixture shall be heated in the reaction flask just to boiling. A red or pink coloration of the cuprous ammonium chloride solution in the test tube indicates that the magnesium sample contains more than 0.004 percent carbides. Should the cuprous ammonium chloride solution become blue, due to the introduction of air, it shall be decolorized with successive 5 ml. portions of hydroxylamine hydrochloride reagent until the blue color disappears.

How to Build Flash/Stun Grenades

MIL-P-14067B(MU)
10 March 1967

4.3.4 Alloyed iron as Fe. -Code number 06001. An accurately weighed portion of approximately 10 gm. of the sample shall be transferred to a 500 ml. flask. About 200 ml. of 1:5 H₂SO₄ shall be added slowly, to minimize effervescence and prevent spattering. The solution shall be allowed to stand until action ceases and all the magnesium has dissolved. The solution shall be titrated immediately with 0.02N KMnO₄ solution. The percent alloyed iron shall be calculated as follows:

$$\text{Percent alloyed iron as FE} = \frac{5.584 \text{ VN}}{W}$$

where:

V = ml. KMnO₄ required for sample.

N = Normality of KMnO₄ solution.

W = gm. of sample

4.3.5 Free metallic magnesium (eudiometer method). Code number 07001. The free metallic magnesium shall be determined in accordance with method 412.1 of Standard MIL-STD-1234.

4.3.6 Zinc (see 4.3.16). Code number 08001. Ammonium Mercuric Thiocyanate Method or Zinc Oxide Method. The zinc content shall be determined in accordance with Method ASTM Designation E 34-58.

4.3.7 Other impurities. Code 09001. The sum of the percentages of volatile material, carbides, alloyed iron, free metallic magnesium and zinc shall be subtracted from 100 percent. The remainder shall be percentage of other impurities.

4.3.8 Oil and grease. -Code number 10001. A weighed portion of approximately 20 gm. of the sample shall be extracted with ether in a Soxhlet or similar extractor using a tared flask. The ether shall be evaporated when extraction is completed and the flask and contents shall be dried at 90°C. to constant weight, cooled in a desiccator, and weighed. A blank shall be run at the same time. The weight of residue shall be calculated to percent oil and grease, as follows:

$$\text{Percent of oil and grease} = \frac{(A-B)}{W} 100$$

Where:

A = weight of ether extract.

B = weight of blank.

C = weight of sample.

Notes and References

MIL-P-14067B(MU)
10 March 1967

4.3.9 Silicon as Si. -Code number 11001. The silicon content shall be determined in accordance with the mixed acid method of ASSTM designation E-34-58.

4.3.10 Free metallic aluminum (eudiometer method). -Code number 12001. The free metallic aluminum shall be determined as specified in method 412.1 of Standard MIL-STD-1234. Except that the reaction flask shall contain 100 ml. 10 percent sodium hydroxide solution saturated with hydrogen. At Standard conditions a 0.33 to 0.34 gm. sample shall be used and calculated as follows:

$$\text{percent free metallic aluminum} = \frac{0.0288V(P_1 - P_2)}{W(273 \text{ plus } T)} \quad (0.275A \text{ plus } 1.28B)$$

where;

T = temperature of water jacket in °C.

V = volume of gas in buret, ml.

P₁ = barometric pressure, in mm. of mercury.

P₂ = vapor pressure of water at T, in mm. of mercury.

W = weight of sample, gm.

A = percent zinc.

B = percent silicon.

4.3.11 Test applicable to type III, magnesium-aluminum alloy powdered 65/35, atomized.

4.3.11.1 Aluminum. -Code number 13001.

4.3.11.1.1 Preparation of solutions.

4.3.11.1.1.1. 8-Hydroxyquinoline solution. -Five gm. of 8-hydroxyquinoline shall be dissolved in 10 ml. of glacial acetic acid. The solution shall be diluted to 100 ml. with water and filtered, if necessary.

4.3.11.1.1.2 Bromphenol blue indicator. -Into 20 ml. of 95 percent ethyl alcohol 0.100 gm. of bromphenol blue powder shall be dissolved and diluted to 100 ml. with water.

How to Build Flash/Stun Grenades

MIL-P-14067B(MU)
10 March 1967

4.3.11.1.2 Procedure. An accurately weighed sample of 0.7700 plus or minus 0.0300 gm. of Type III alloy shall be transferred to a 250 ml. beaker. Ten ml. of water, shall be added. The beaker shall be covered with a watch glass and 20 ml. of concentrated HCl shall be added dropwise through the opening at the lip of the beaker. After the reaction has subsided, the solution shall be heated to boiling to assure complete solution. The watch glass shall be washed thoroughly and the washings drained back into the beaker. The solution shall be filtered through a No. 41 Whatman, or equivalent, filter paper. The filtrate shall be caught in an accurately calibrated, 1-liter volumetric flask. The filter paper shall be washed thoroughly with hot water and the solution made up to volume with water. A 100 ml. aliquot shall be transferred to a 250 ml. beaker using an accurately calibrated buret or pipet. Three drops of bromphenol blue indicator shall be added and the solution neutralized by adding dropwise and with constant stirring, a filtered 1:1 NH_4OH solution until the yellow color turns to blue. Two drops of NH_4OH solution shall then be added in excess. The solution shall be heated to boiling and 18 ml. of the 8-hydroxyquinoline solution added in small portions, stirring after each addition to dissolve the precipitate that forms. Any precipitate remaining after the completion of the addition of the reagent shall be disregarded. The solution shall be heated to boiling and 40 ml. of 2 molar (M) ammonium acetate solution (154 gm. per liter) added dropwise with vigorous stirring and then placed on a steam bath for 30 minutes. The solution shall be filtered with a suction through a tared, fine porosity, fritted glass bottom crucible. The precipitate shall be washed eight times with 15 ml. portion of water, releasing the suction before each addition and allowing the precipitate to remain in contact with the wash water for at least 1 minute prior to the application of suction. The precipitate shall be dried for 3 hours in an oven at 120 to 140° C, cooled in a desiccator and weighed as aluminum hydroxyquinoline, $\text{Al}(\text{C}_9\text{H}_6\text{ON})_3$. The percent aluminum shall be calculated as follows:

$$\text{Percent aluminum} = \frac{A - 0.0874BW}{W} \times 5.87$$

Where:

A = gm of precipitate.

B = percent iron.

W = gm. of sample contained in the aliquot.

Notes and References

MIL-P14067B(MU)
10 March 1967

4.3.11.2 Magnesium. Code number 14001. An 100 ml aliquot of the solution, prepared as specified in 4.3.11.1.2, shall be transferred to a 400 ml beaker by means of an accurately calibrated buret or pipet. Three drops of bromphenol blue indicator shall be added and the solution neutralized with filtered 1:1 NH_4OH solution until the yellow color changes to blue. One gm of ammonium chloride and 1 ml of glacial acetic acid shall be added to the solution. Twenty ml of hot 10 percent ammonium benzoate solution shall be added slowly while stirring. The solution shall be heated on a hot plate and boiled gently for 5 minutes. Then filtered through Whatman No. 41, or equivalent, filter paper catching the filtrate in a 600 ml beaker. The precipitate shall be washed 10 times with a hot wash solution containing 1 gm of ammonium benzoate and 2 ml of glacial acetic acid per 100 ml of solution. Any crystallization that occurs in the filtrate as it cools shall be disregarded. The combined filtrate and washing shall be made alkaline to phenolphthalein with filtered concentrated NH_4OH solution. Five ml of NH_4OH solution shall be added in excess. The solution shall be heated from 60° to 70° and 15 ml of 8-hydroxyquinoline solution added rapidly drops from a buret. The liquid shall be stirred vigorously with a thermometer keeping the temperature of the solution at 60° to 70° C during addition. The solution shall be heated almost to boiling with frequent stirring and transferred to a steam bath for 20 minutes. The solution shall be filtered through a tared, fine porosity, sintered glass bottom crucible. The suction shall be disconnected and 10 ml of warm 1:10 NH_4OH wash solution added to the precipitate with a wash bottle agitating the precipitate as much as possible with the force of the steam of wash solution. The suction shall be applied until the precipitate remains only moist enough to prevent cracking. This procedure shall be repeated 7 times finally washing with two 10 ml portions of cold water. The precipitate shall be dried to constant weight in an oven at 155° to 160° C., cooled in a desiccator, and weighed. The percent magnesium shall be calculated as follows:

$$\text{Percent magnesium} = \frac{7.78A}{W}$$

Where:

A = gram precipitate

W = gram of sample contained in aliquot.

How to Build Flash/Stun Grenades

MIL-P-14067B(MU)
10 March 1967

4.3.12 Total aluminum and magnesium. Code number 15001. The percentages of aluminum and magnesium as determined in 4.3.11.1 and 4.3.11.2 shall be added to obtain the total aluminum and magnesium.

4.3.13 Determination of average particle diameter (all types). Code number 16001. -The average particle diameter of metal powders shall be determined by means of an instrument based on the air permeability principle such as the Fisher Sub Sieve Sizer or Picatinny Particle Sizer. The average particle size shall be determined in accordance with Standard MIL-STD-1233, Method 100 for the Fisher Sub Sieve Sizer and Method 200 for the Picatinny Arsenal Particle Sizer.

4.3.14 Apparent density (all types). Code number 17001. -A funnel having a stem of 1/4 inch internal diameter shall be cut so that the tip of the stem is just above the uppermost graduation of a tared 100 ml. graduated cylinder. The cylinder shall be filled to the 100 ml. mark by pouring small quantities of the sample on the side of the funnel and allowing it to fall by gravity through the stem. Jarring or tapping of the cylinder shall be avoided. The cylinder shall be weighed and the gain in weight divided by 100 shall be reported as the apparent density.

4.3.15 Granulation (all types). Code number 18001. -The granulation shall be determined in accordance with Method 201.1 of Standard MIL-STD-1234.

4.3.16 Spectrochemical Analysis (alternate method). A spectrochemical analysis shall be determined for alloyed iron, zinc, and silicon in accordance with Federal Standards, Federal Test Method Standard No. 151, method 112.

4.3.17 Ellipsoidal Type IV. Code Number 19001. -Microscopic Analysis. One hundred particles shall be examined under a microscope with a magnification of 50. Each particle shall be counted individually and the percentage of oblong particles shall be determined.

4.3.18 Nitrogen. Code number 20001. (Type I and IV). Weigh four grams of powder into 250 ml. beakers. Add 25 ml. water and cover with watch glasses. Add 20 ml. concentrated sulfuric acid in small increments. When solution is completed, transfer to 100 ml. volumetric flask and dilute to volume with ammonia free distilled water. After thoroughly mixing, pipette a 25 ml. aliquot into the Kjeldahl flask. Add 150 ml. ammonia free water and 35 ml. 30 percent sodium hydroxide solution and connect to steam distillation assembly.

Notes and References

MIL-P-14067B(MU)
10 March 1967

Place the delivery tube from the condenser below the surface of 10 ml. of N/50 sulfuric acid in 100 ml. volumetric flask or 100 ml. beaker. Distill at the rate of 3 to 5 ml. per minute until the volume is approximately 90 ml. Transfer to 100 ml. volumetric flask unless this was used to receive the distillate. Add 2 ml. Nessler's (see Note 4) reagent and make to volume and mix. Wait 3 to 5 minutes and read on the photometer preferably using a cell provided 4 cm. for the light path. If the Klett type instrument is available, use the blue filter. For the wave length selector type instruments, set the wave length to obtain the maximum absorbance. Run the blank in the same manner and subtract the blank reading from the sample. Obtain micrograms nitrogen from the calibration curve. Prepare the calibration curve to cover the range. 0-80 micrograms nitrogen. Use ammonium chloride as the source of nitrogen.

Calculations

$$\text{PPM M2} = \frac{\text{Micrograms N}_2}{\text{Sample Weight (grams)} \times \text{Aliquot}}$$

NOTES:

Note 1) It is often difficult to remove the last traces of ammonia from the distillation equipment. This must be done by continuous distillation from alkaline aqueous solutions (make alkaline with sodium hydroxide) until approximately 80 ml. of the distillate + 10 ml N/50 sulfuric acid + 2 ml. Nessler's reagent made to 100 ml. volume gives essentially the same reading as 10 ml. N/50 sulfuric acid + 80 ml. ammonia free distilled water + 2 ml. Nessler's reagent made to 100 ml. volume.

Note 2) The presence of ammonia fumes in the laboratory necessitate frequent blank checks.

Note 3) The ammonia free water is prepared by boiling distilled water made alkaline with sodium hydroxide. Portions of distillate are discarded until they cease to develop color with Nessler's reagent.

Note 4) Nessler's reagent- dissolve 50 g. potassium iodide in the smallest possible quantity of cold water. Add a saturated solution of mercuric chloride until a faint show of excess is indicated. Add 400 ml. of 50 percent KOH solution. After the solution has clarified by settling, make up to 1 liter with water, allow to settle and decant.

How to Build Flash/Stun Grenades

MIL-P-14067B(MU)
10 March 1967

5. PREPARATION FOR DELIVERY

5.1 Packing. -Unless otherwise specified on the contract or order, powder shall be shipped in unlined, full open head steel drums protected against corrosion and conforming to the requirements of ICC Specification 37A or B stipulated in the Code of Federal Regulations 49 CFR 71-90. Containers shall contain a maximum of 150 pounds. Each drum shall be provided with a tubular rubber cover gasket, firmly cemented in place. When the jackscrew is tightened, the rim shall be tapped with a mallet to insure complete and proper sealing of the gasket. If a drum is to be reused for the shipment of powder, new gaskets shall be used each time. In addition, each drum reused shall pass the tests and conditions for new drums.

5.2 Markings. -Marking to insure safe handling shall conform to the ICC Regulations stipulated in the Code of Federal Regulations 49 CFR 71-90 and in addition shipments shall be marked in accordance with Standard MIL-STD-129. Unless otherwise specified, each container shall be plainly marked with the following information completed:

- (1) Minimum percentage of free metallic magnesium or aluminum.
- (2) Type of powder (Type I, II, III, IV)
- (3) Nominal mesh size.

6. NOTES

6.1 Intended use. -These metal powders are intended for use in pyrotechnics compositions.

6.2 Ordering data. -Procurement documents should specify the following:

- (1) Title, number, and date of this publication.
- (2) Type of metal powder (see 1.2).
- (3) Granulation and average particle diameter required (see 3.3 and 3.4).

Notes and References

MIL-P-14067B(MU)

10 March 1967

6.3 "Atomization" is defined as the dispersion of a molten metal into a spray, the droplets of which are then allowed to freeze under the primary influence of surface tension. "Granular" is defined as particles that have approximately equi-dimensional non spherical shapes.

6.4 Inspection code numbers. -The five digit code numbers assigned to the inspection herein are to facilitate future data collection and analysis by the Government.

6.5 Ellipsoidal particles are made by chipping magnesium ingots and then hammering the particles in a hammering machine.

6.6 An oblong particle is one that has a length/width ratio greater than 1:5.

Custodian:

Army-MU

Preparing Activity:

Army-MU

Project Number: 6810-A149

• U. S. GOVERNMENT PRINTING OFFICE - 1967: 253-227 X 1199

— Notes —

How to Build Flash/Stun Grenades

by
George Dmitrieff

George Dmitrieff noted author of firearms and ammunition publications takes you into the realm of exotic defensive munitions with this excellent treatise on the flash/stun grenade. It covers all the basic fundamentals of the military grenades, both simulation and actual. There are step by step instructions for developing your own flash weapons which include construction of the device and mixtures for charging.

The format of this presentation features simple design, simple processes and common language terms without sacrificing product performance. This is one of the most comprehensive texts on the subject to be released to the general public.

The author emphasizes that the processes described herein are dangerous due to the sensitive nature of materials used. Furthermore, construction of these devices is subject to Federal, State and local laws and regulations requiring special licenses.

A MUST FOR THE ENTHUSIAST'S OR TECHNOLOGIST'S LIBRARY!

Desert Publications

A division of Delta Group

215 S. Washington

El Dorado, AR 71730 U. S. A.

ISBN 0-87947-182-4



9 780879 471828